

# AUTOMATIC ELECTRIC ANTENNA

AM/FM



**EN** The new generation of automatic electric antennas for analogue AM/FM radio reception is conceived as a solid and easy-to-install product. It can be adopted on a wide range of car models, featuring a universal base and allowing to reduce the drilling hole diameter on vehicle. The new automatic electric antenna is manufactured with high quality and long lasting materials to grant an excellent and steady performance in all operating conditions.

**IT** La nuova generazione di antenne elettriche automatiche per la ricezione della radio analogica AM/FM sono compatte e semplici da installare in un'ampia gamma di automobili grazie al diametro di foratura ridotto e allo snodo universale. Sono costruite con materiali e componenti di elevata qualità per durare nel tempo e offrire prestazioni costanti in ogni condizione

## Dimensions / Dimensioni

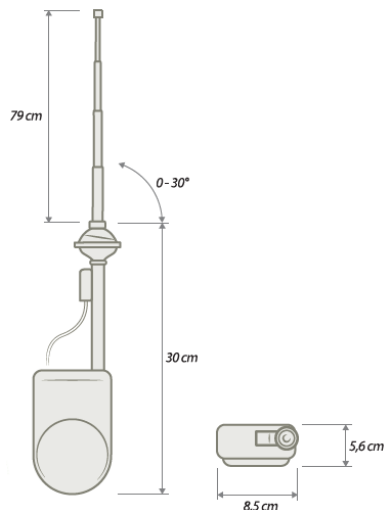

## Mounting position / Posizioni di montaggio

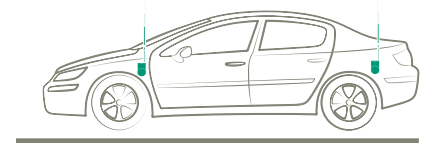

## Coachwork drilling / Foro Carrozzeria



Ø 14,5 mm

## ROD COLOR - COLORE ASTA

P/N 7677154	INOX
P/N 7677155	BLACK

## COMMON TECHNICAL SPECIFICATION - SPECIFICHE TECNICHE COMUNI

Frequency - Frequenza	AM = 0,15 ÷ 1,71 MHz	FM = 87,5 ÷ 108 MHz	
Rod - Asta	Lenght: 79 cm	Sections: 5	Material: Stainless Steel
Rod angle - Inclinazione asta	Max 30 degree from vertical position		
Cable - Cable	Lenght: 140 cm	Type: 3C-2V	
Connector - Connettore	DIN male		
Power supply - Alimentazione	+ 12 volt		
Consumption - Consumo	Typical: 24 watt	Max: 36 watt	
Mounting - Installazione	Fender / Pillar		
Coachwork drilling - Foro carrozzeria	Max diameter: 14,5 mm		
Temperature - Temperatura	Storage: from - 30° C to + 80° C	Working: from 20° C to + 70° C	

Specifications subject to change without prior notice - Specifiche tecniche passibili di modifica senza preavviso

