



## INSTALLATION INSTRUCTIONS FOR PART INST-6000

### APPLICATIONS

# Chrysler/Ford/Mitsubishi 1974-2003\* INST-6000

## INSTALLATION INSTRUCTION

---

- 99-6000 • 99-6501 • 99-7000
- 99-6500 • 99-6700

*\* Vehicles that apply within stated year range. Refer to each application section for specific model and year(s) installation instructions.*

## TOOLS REQUIRED

---

*Refer to each section title page.*

*INST-6000 is a collection of installation instruction booklets. Use the Application Overview when selecting which installation instruction selection to use. Each section is setup as a chapter with its own table of contents.*

## Application Overview

### 99-6000

Chrysler/Dodge/Eagle/Jeep/  
Plymouth 1974-2003\*\*

### 99-6500

Chrysler/Dodge/Eagle/Ford/  
Jeep/Lincoln/Mercury/  
Plymouth 1974-2003\*\*

### 99-6501

Chrysler/Dodge/Eagle/Jeep/  
Lincoln/Mercury/Plymouth  
1974-2003\*\*

### 99-6700

Crysler/Eagle/Ford/  
Jeep 1974-2003\*\*

### 99-7000

Dodge/Eagle/Mitsubishi/  
Plymouth 1985-1996\*\*

*\*\* Vehicles that apply within stated year range. Refer to each application section for specific model and year(s) installation instructions.*

---

**CAUTION:** *Metra recommends disconnecting the negative battery terminal before beginning any installation. All accessories, switches, and especially air bag indicator lights must be plugged in before reconnecting the battery or cycling the ignition.*

**NOTE:** *Refer to the instructions included with the aftermarket radio.*

## Contents

Installation Instructions	Section
- 99-6000** .....	1.0
- 99-6500** .....	2.0
- 99-6501** .....	3.0
- 99-6700** .....	4.0
- 99-7000** .....	5.0
- Dash Disassembles.....	6.0
<i>(99-6000, 99-6500, 99-6501, 99-6700)</i>	

## Section 1

# Chrysler/Dodge/Jeep/ Plymouth 1974-2003 99-6000

### KIT FEATURES

- Pocket provisions

### KIT COMPONENTS

- A) Radio housing

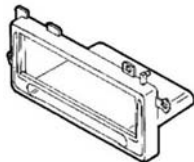
**A**

### TOOLS REQUIRED

- Phillips screwdriver • Panel removal tool • Cutting tool

## Applications

<b>Chrysler</b>	<b>Dodge (continued)</b>	<b>Jeep</b>
Cirrus 1995-2000	Lancer 1986-1989	Cherokee 1997-2001
Concorde 1993-1997	Magnum XE	Grand Cherokee
Cordoba 1975-1983	1978-1997	1993-1995
E-Class 1983-1993	Mirada 1979-1989	Grand Cherokee
5th Avenue	Neon 1995-1999	1996-1998
1979-1993	Omni 1978-1990	Wrangler 1997-2002
Imperial 1982-1983	Pick-up 1974-1983	
Imperial 1990-1993	Ram 1994-2001	<b>Plymouth</b>
Laser 1984-1989	Ramcharger	Acclaim 1989-1995
LeBaron 1977-1995	1974-1993	Breeze 1996-1999
LeBaron GTS	Rampage 1978-1982	Caravelle 1985-1987
1985-1995	Shadow 1987-1995	Fury 1975-1978
LHS 1993-1998	Spirit 1989-1995	Gran Fury 1978-1989
Newport 1977-1981	St. Regis 1979-1981	Horizon 1978-1983
New Yorker	Stratus 1995-1999	Neon 1994-1999
1975-1996	Van 1978-2003	Reliant 1981-1989
Sebring 1995-2000	024 1978-1982	Scamp 1983-1984
Sebring (conv)	400 1982-1983	Sundance 1987-1994
1996-1999	600 1983-1987	TC3 1978-1982
Town & Country		Trailduster
1990-2000	<b>Ford</b>	1975-1981
	Aerostar 1985-1991	Turismo 1983-1987
	Bronco II 1983-1988	Van 1978-1997
<b>Dodge</b>	Country Squire	Volare 1976-1980
Aries 1981-1989	1979-1989	Voyager 1984-2000
Aspen 1976-1980		
Avenger 1995-2000	Crown Victoria	<b>Mitsubishi</b>
Caravan 1984-2000	1983-1989	Galant 1989-1993
Charger 1974-1978	LTD 1979-1986	Galant 1985-1988
Charger 1981-1987	Ranger (mini)	Sigma 1989-1990
Dakota 1987-2000	1983-1988	Van 1987-1990
Daytona 1984-1993	Thunderbird	
Diplomat 1976-1989	1980-1988	
Durango 1998-2000		
Dynasty 1988-1993	<b>Eagle</b>	
Intrepid 1993-1997	Vision 1993-1997	

\*\*INST-6000 is a collection of installation instruction booklets. Use the Application Overview when selecting which installation instruction selection to use. Each section is setup as a chapter with its own table of contents.

## Table of Contents 99-6000

### Kit Preparation

- Chrysler/Dodge/Eagle/Jeep/Plymouth\*\* ..... 1.1  
*(Except: Grand Cherokee 1993-1995, Cirrus, Stratus, Sebring, Sebring convertible, and Avenger)*
- Chrysler Cirrus 1995-2000\*\* ..... 1.1
- Chrysler Sebring (convertible) 1996-2000\*\* ..... 1.1
- Chrysler Sebring 1995-2000\*\* ..... 1.2
- Dodge Avenger 1995-2000\*\* ..... 1.2
- Dodge Stratus 1995-1999\*\* ..... 1.1
- Jeep Grand Cherokee 1993-1995\*\* ..... 1.2
- Plymouth Breeze 1996-1999\*\* ..... 1.1

### Kit Assembly

- DIN radio provision ..... 1.2

**\*\*ATTENTION:** Please refer to **Section 6** for **Dash Disassembles**.

**Attention:** This kit (99-6000) has been specially designed with support ribs to insure structural integrity during shipping. Please cut and remove these ribs from the radio opening before beginning your installation.

## Chrysler/Dodge/Eagle/ Jeep/Plymouth

*(Except: Grand Cherokee 1993-1995, Cirrus, Stratus, Sebring, Sebring convertible, and Avenger)*

1. Cut and remove all mounting tabs on the **Radio Housing EXCEPT** the shaded tabs.
2. Cut and remove the lower locating pin on tab "A". *It may be necessary to trim tabs "B" for some applications.*

*Continue to kit assembly, p. 1.2*

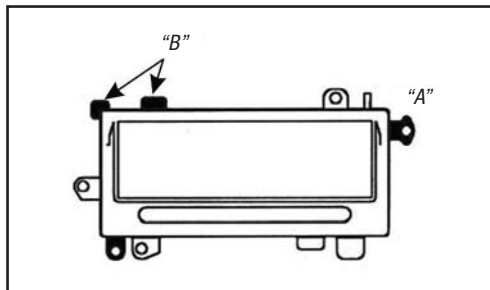

## Chrysler Cirrus 1995- 2000/Sebring (convertible) 1996-2000, Dodge Stratus 1995-1999/Plymouth Breeze 1996-1999

1. Cut and remove all mounting tabs on the **Radio Housing EXCEPT** the shaded tabs.
2. Cut and remove the upper locating pin on tab "A".

*Continue to kit assembly, p. 1.2*

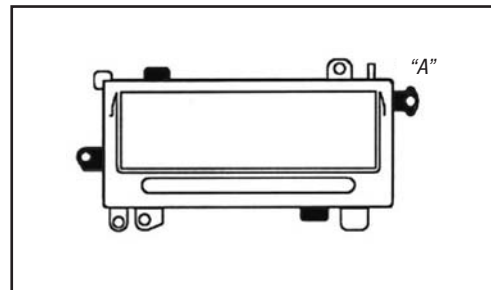

## Chrysler Sebring/Dodge Avenger 1995-2000

Cut and remove all mounting tabs on the the shaded tabs.

*Continue to kit assembly, p. 1.2*

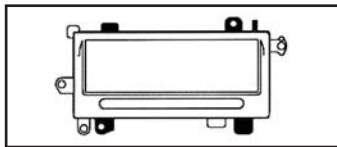

## Jeep Grand Cherokee 1993-1995

1. Cut and remove all mounting tabs on the **Radio Housing EXCEPT** the shaded tabs.
2. Cut tab "A" along the scored line and remove the bottom portion of the tab.

*Continue to kit assembly, p. 1.2*

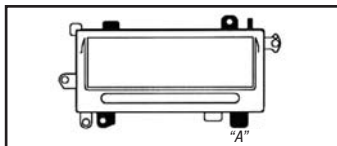

## DIN radio provision

1. Slide the DIN cage into the kit and secure by bending the metal locking tabs down.
2. Slide the aftermarket radio into the cage until secure. (Figure A)
3. Locate the factory wiring harness in the dash. Metra recommends using the proper mating adapter from Metra or AXXESS Re-connect the negative battery terminal and test the unit for proper operation.
4. Reassemble dash in reverse order of disassembly. (Figure B)

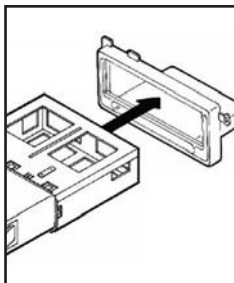

(Figure A)

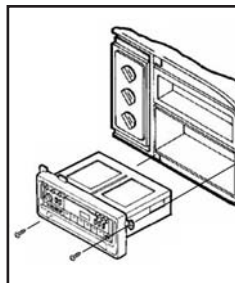

(Figure B)

## Section 2

### Chrysler/Dodge/Eagle/ Ford/Jeep/Lincoln/Mercury/ Plymouth 1974-2003 99-6500

#### KIT FEATURES

- DIN radio provision

#### KIT COMPONENTS

- A) Radio housing

A

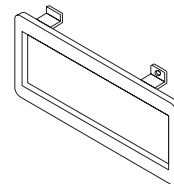

#### TOOLS REQUIRED

- Phillips screwdriver • Socket wrench • Cutting tool

## Applications

<b>Chrysler</b>	<b>Dodge</b> <i>(continued)</i>	<b>Jeep</b> <i>(continued)</i>
Concorde 1993-1997	Magnum XE	Wrangler 1997-2002
Cordoba 1975-1983	1978-1979	
E-Class 1983-1993	Mirada 1979-1983	<b>Lincoln</b>
Fifth Avenue	Neon 1994-1999	Continental
1979-1993	Omni 1978-1982	1985-1989
Imperial 1982-1983	Pick-up 1974-1983	Mark VII 1984-1988
Imperial 1990-1994	Ram 1994-2000	
Laser 1984-1989	Ramcharger	<b>Mercury</b>
LeBaron 1977-1995	1974-1993	Colony Park
LeBaron GTS	Rampage 1978-1982	1979-1989
1985-1994	Shadow 1987-1995	Cougar 1983-1988
LHS 1995-1998	Spirit 1989-1995	Cougar XR7
Newport 1977-1980	St. Regis 1979-1981	1980-1982
New Yorker	Van 1978-2003	Grand Marquis
1975-1996		1979-1985
Town & Country	<b>Eagle</b>	Marquis 1979-1988
1990-2000	Vision 1993-1997	
		<b>Plymouth</b>
<b>Dodge</b>	<b>Ford</b>	Acclaim 1989-1995
024 1978-1982	Aerostar 1985-1991	Caravelle 1985-1988
400 1982-1983	Bronco II 1983-1988	Fury 1975-1978
600 1983-1987	Country Squire	Gran Fury 1978-1989
Aries 1981-1989	1979-1989	Horizon 1978-1983
Aspen 1976-1980	Crown Victoria	Neon 1994-1999
Caravan 1984-2000	1983-1989	Reliant 1981-1989
Charger 1974-1978	LTD 1979-1986	Scamp 1983-1984
Charger 1981-1987	Ranger <i>(mini)</i>	Sundance 1987-1994
Dakota 1987-2000	1983-1988	TC3 1978-1982
Daytona 1984-1993	Thunderbird	Trailduster
Diplomat 1976-1989	1980-1988	1975-1981
Durango 1998-2000		Turismo 1983-1987
Dynasty 1988-1993	<b>Jeep</b>	Van 1978-1997
Intrepid 1993-1997	Cherokee 1997-2001	Volare 1976-1980
Lancer 1985-1989	Grand Cherokee	Voyager 1984-2000
	1996-1998	

## Table of Contents

### 99-6500

#### Kit Preparation

- Chrysler 1975-2000**	2.1
- Dodge 1974-2003**	2.1
- Eagle 1993-1997**	2.1
- Ford 1979-1991**	2.1
- Jeep 1996-2002**	2.1
- Lincoln 1984-1989**	2.1
- Mercury 1979-1989**	2.1
- Plymouth 1975-2000**	2.1

#### Kit Assembly

- DIN radio provision	2.2
-----------------------	-----

**\*\*ATTENTION:** Please refer to Section 6 for **Dash Disassembles.**

## Chrysler/Dodge/Eagle/Jeep/ Plymouth 1974-2003

1. Cut and remove all mounting tabs on the **Radio Housing EXCEPT** the shaded tabs. *It may be necessary to trim tabs "B" for some applications.*

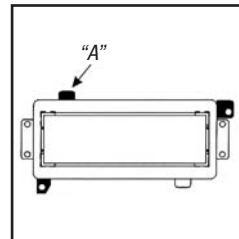

*Continue to kit assembly, p. 2.2*

## Ford/Lincoln/Mercury 1974-2003

1. Cut and remove all mounting tabs on the **Radio Housing EXCEPT** the shaded tabs.

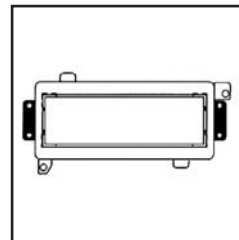

*Continue to kit assembly, p. 2.2*

## DIN radio provision

1. Remove the metal "DIN" cage from your aftermarket radio.
2. Slide the cage into the kit and secure by bending the metal locking tabs down.
3. Locate the factory wiring harness in the dash. Metra recommends using the proper mating adapter from Metra or AXCESS. Re-connect the negative battery terminal and test the unit for proper operation.
4. Slide the aftermarket radio into the cage until secure. (Figure A)
5. Reassemble dash in reverse order of disassembly. (Figure B)

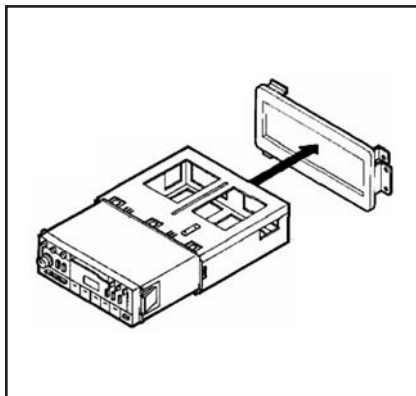

(Figure A)

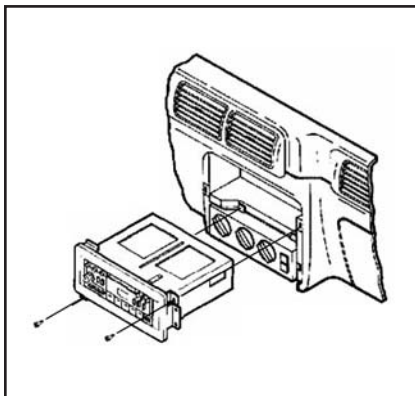

(Figure B)

## Section 3

### Chrysler/Dodge/Eagle/Ford/ Jeep/Lincoln/Mercury/ Plymouth 1974-2003 99-6501

#### KIT FEATURES

- DIN and ISO DIN provisions

#### KIT COMPONENTS

- A) Radio housing • B) ISO DIN faceplate
- C) Spacer • D) Snap spacers • E) (2) ISO DIN brackets
- F) (4) 5mm flat-head screws • G) (2) #6 Self-tapping screws

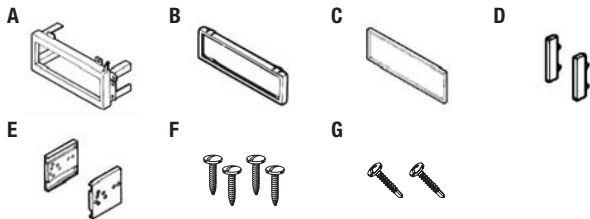

#### TOOLS REQUIRED

- Phillips screwdriver • Socket wrench • Cutting tool

## Applications

<b>Chrysler</b>	<b>Dodge</b> <i>(continued)</i>	<b>Mercury</b>
Concorde 1993-1997	Diplomat 1976-1989	Colony Park 1979-1989
Cordoba 1975-1983	Durango 1998-2000	Cougar 1983-1988
E-Class 1983-1993	Dynasty 1988-1993	Cougar XR7 1980-1982
5th Ave 1979-1993	Intrepid 1993-1997	Grand Marquis 1979-1985
Imperial 1982-1983	Lancer 1985-1989	Marquis 1979-1985
Imperial 1990-1994	Magnum XE 1978-1979	<b>Plymouth</b>
Laser 1984-1989	Mirada 1979-1983	Acclaim 1989-1995
LeBaron 1977-1995	Neon 1994-1999	Caravelle 1985-1987
LeBaron GTS 1985-1994	Omni 1978-1982	Fury 1975-1978
LHS 1995-1998	Pick-up 1974-1983	Gran Fury 1975-1985
Newport 1977-1980	Ram 1994-2000	Horizon 1978-1982
New Yorker 1975-1996	Spirit 1989-1995	Neon 1994-1999
Town & Country 1990-2000	St. Regis 1979-1981	Reliant 1981-1989
	Van 1978-2003	Scamp 1983-1984
	<b>Jeep</b>	Sundance 1987-1994
<b>Dodge</b>	Cherokee 1997-2000	TC3 1978-1982
024 1978-1982	Grand Cherokee 1993-1995	Trailduster 1974-1980
400 1982-1983	Grand Cherokee 1996-1998	Trailduster 1981
600 1983-1987	Wrangler 1997-2000	Turismo 1983-1987
Aries 1981-1989		Van 1978-1997
Aspen 1976-1980	<b>Lincoln</b>	Volare 1976-1980
Caravan 1984-2000	Continental 1984-1988	
Charger 1974-1978	Mark VII 1984-1989	
Charger 1981-1987		
Dakota 1987-2000		
Daytona 1984-1993		

## Table of Contents

### 99-6501

#### Kit Preparation

- Chrysler/Dodge/Eagle/Jeep/Plymouth\*\* ..... 3.1  
*(Except: Grand Cherokee 1993-1995, Sebring and Avenger)*
- Chrysler Sebring 1995-2000\*\* ..... 3.2
- Dodge Avenger 1995-2000\*\* ..... 3.2
- Ford/Lincoln/Mercury 1979-1989\*\* ..... 3.2
- Jeep Grand Cherokee 1993-1995\*\* ..... 3.2

#### Kit Assembly

- ISO DIN radio provision..... 3.2-3.3
- DIN radio provision..... 3.3

**\*\*ATTENTION: Please refer to Section 6 for Dash Disassembles.**

## Chrysler/Dodge/Eagle/Jeep/Plymouth

*(Except: Grand Cherokee 1993-1995, Sebring and Avenger)*

1. Cut and remove all mounting tabs on the **Radio Housing EXCEPT** the shaded tabs. *It may be necessary to trim tabs "A" for some applications.*

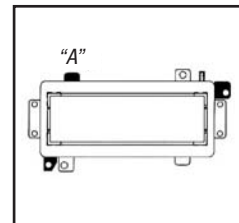

*Continue to kit assembly, p. 3.2-3*

### **Ford/Lincoln/Mercury 1979-1989**

1. Cut and remove all mounting tabs on the **Radio Housing** EXCEPT the shaded tabs.

*Continue to kit assembly, p. 3.2-3*

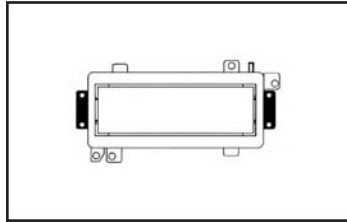

### **Chrysler Sebring/Dodge Avenger 1995-2000, Jeep Grand Cherokee 1993-1995**

1. Cut and remove all mounting tabs on the **Radio Housing** EXCEPT the shaded tabs.

*Continue to kit assembly, p. 3.2-3*

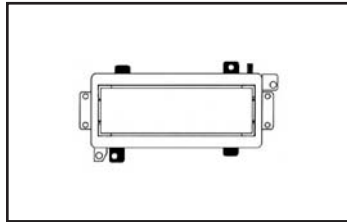

### **ISO DIN radio provision**

1. Snap the ISO DIN faceplate into the radio housing and then slide the aftermarket radio into the back of the kit.
2. Slide the ISO DIN brackets onto the housing legs and align the holes in the brackets with the holes in the unit.
3. Mount the brackets to the unit with (4) 5mm Flat-head screws supplied ("A"). (Figure A)

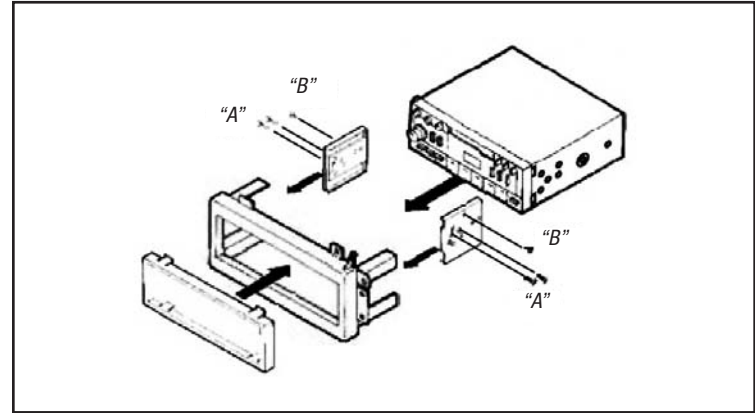

(Figure A)



### ISO DIN radio provision

- Mount the brackets to the top of the housing legs with (2) #6 Self-tapping screws ("B"). (Figure A)
- Locate the factory wiring harness in the dash. Metra recommends using the proper mating adapter from Metra or AXCESS. Re-connect the negative battery terminal and test the unit for proper operation.
- Reassemble dash in reverse order of disassembly.

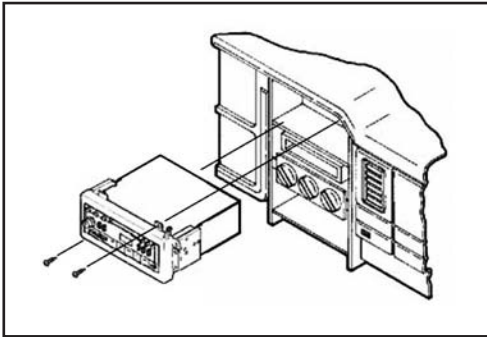

(Figure B)

### DIN radio provision

- If a **surface-mount installation** is desired, insert the spacer into the radio housing. (Figure A)
- Slide the DIN cage into the kit and secure by bending the metal locking tabs down. Slide the aftermarket radio into the cage until secure.
- If an **intermediate mount** installation is desired, attach the snap spacers to the outer walls of the radio opening. (Figure B)
- Slide the DIN cage into the radio housing and secure by bending the metal locking tabs down. Slide the aftermarket radio into the cage until secure.
- If a **flush-mount installation** is desired, slide the DIN cage into the radio housing and secure by bending the metal locking tabs down. (Figure C)
- Slide the aftermarket radio into the cage until secure.
- Locate the factory wiring harness in the dash. Metra recommends using the proper mating adapter from Metra or AXCESS. Re-connect the negative battery terminal and test the unit for proper operation.
- Reassemble dash in reverse order of disassembly.

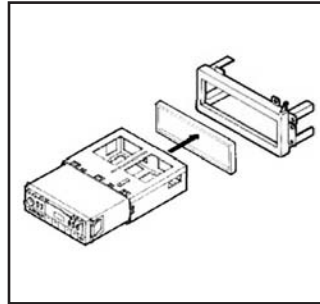

(Figure A)

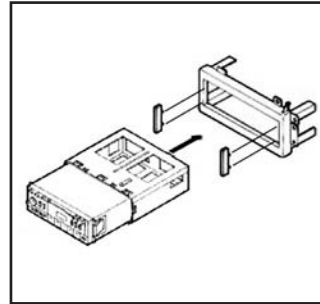

(Figure B)

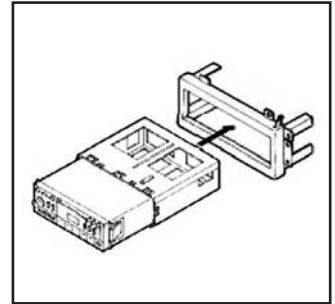

(Figure C)

## Section 4

# Chrysler/Eagle/Ford/ Jeep 1974-2003 99-6700

### KIT FEATURES

- Recessed DIN for flush mount provision

### KIT COMPONENTS

- A) Radio housing • B) Support spacers (*Avenger/Sebring*)

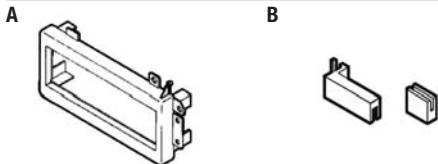

### TOOLS REQUIRED

- Phillips screwdriver • Cutting tool • Socket wrench

## Applications

<b>Chrysler</b>	Avenger	1995-2000	400	1982-1983
Cirrus	1995-2000	Caravan	1984-1990	600
Concorde	1993-1997	Caravan	1991-1995	
Cordoba	1975-1978	Caravan	1996-2000	
Cordoba	1979-1983	Charger	1974-1978	
E-Class	1984-1993	Charger	1981-1983	
Fifth Avenue		Dakota	1987-1996	
	1979-1993	Dakota	1997-2000	
Imperial	1982-1983	Daytona	1984-1989	
Imperial	1990-1994	Daytona	1990-1993	
Laser	1984-1989	Diplomat	1976-1989	
LeBaron	1976-1981	Durango	1997-2000	
LeBaron	1984-1985	Dynasty	1988-1993	
LeBaron	1986-1995	Intrepid	1993-1997	
LeBaron GTS		Lancer	1985-1989	
	1985-1994	Magnum XE		1985-1988
LHS	1995-1998		1978-1979	
Newport	1977-1981	Mirada	1979-1982	
New Yorker		Neon	1994-1999	
	1980-1981	Omni	1978-1990	
New Yorker		Pickup	1974-1980	
	1983-1987	Pickup	1981-1993	
New Yorker		Ram	1994-2001	
	1994-1996	Ram 2500/3500		2002
Prowler	1997-2002			
Sebring	1995-2000	Ramcharger		
Sebring (conv)			1974-1980	
	1996-2000	Ramcharger		
Town & Country			1981-1993	
	1990-1995	Rampage	1978-1982	
Town & Country		Shadow	1987-1994	
	1996-2000	Spirit	1989-1995	
		St Regis	1979-1981	
<b>Dodge</b>		Stratus	1995-2000	
Aries	1981-1989	Van	1978-2003	
Aspen	1976-1980	024	1978-1982	

## Applications

<b>Plymouth</b>	Reliant	1981-1989	Van	1978-1997
Acclaim	1989-1995	Scamp	1983-1984	Volare
Breeze	1996-1999	Sundance	1987-1994	Voyager
Caravelle	1985-1987	TC3	1978-19821	Voyager
Fury	1975-1978	Trailduster		Voyager
Gran Fury	1975-1985		1974-1980	1996-2000
Horizon	1978-1982	Trailduster	1981	
Neon	1994-1999	Turismo	1983-1987	

## Table of Contents 99-6700

### Dash Disassembly

- Chrysler/Dodge/Eagle/Jeep/Plymouth (*Except: Grand Cherokee 1993-1995, Cirrus, Stratus, Sebring, Sebring convertible, and Avenger*) ..... 4.1
- Chrysler Cirrus 1995-2000/Sebring (*convertible*) 1996-2000, Dodge Stratus 1995-2000, Plymouth Breeze 1996-1999 ..... 4.1
- Chrysler Sebring/Dodge Avenger 1995-2000 ..... 4.1
- Ford/Lincoln/Mercury ..... 4.1
- Jeep Grand Cherokee 1993-1995 ..... 4.1

### Kit Assembly

- DIN radio provision ..... 4.2

### Chrysler/Dodge/Eagle/ Jeep/Plymouth

(Except: Grand Cherokee 1993-1995, Cirrus, Stratus, Sebring, Sebring convertible, and Avenger)

1. Cut and remove all mounting tabs on the **Radio Housing EXCEPT** the shaded tabs.

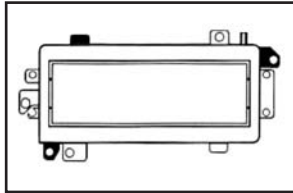

Continue to kit assembly, p. 4.2

### Ford/Lincoln/ Mercury

1. Cut and remove all mounting tabs on the **Radio Housing EXCEPT** the shaded tabs.

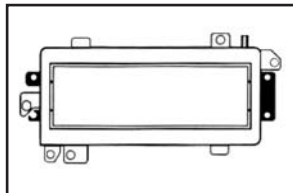

Continue to kit assembly, p. 4.2

### Chrysler Cirrus 1995-2000/ Sebring (convertible) 1996-2000, Dodge Stratus 1995-2000, Plymouth Breeze 1996-1999

1. Cut and remove all mounting tabs on the **Radio Housing EXCEPT** the shaded tabs.

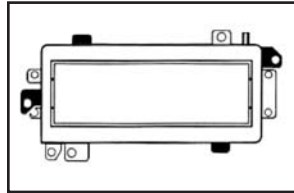

Continue to kit assembly, p. 4.2

### Jeep Grand Cherokee 1993-1995

1. Cut and remove all mounting tabs on the **Radio Housing EXCEPT** the shaded tabs.

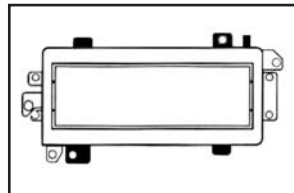

Continue to kit assembly, p. 4.2

### Chrysler Sebring/Dodge Avenger 1995-2000

1. Cut and remove all mounting tabs on the **Radio Housing EXCEPT** the shaded tabs. (Figure A)

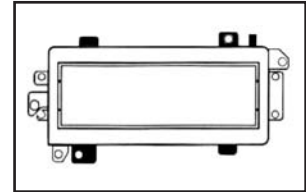

(Figure A)

2. Then attach support spacers as shown. (Figure B)

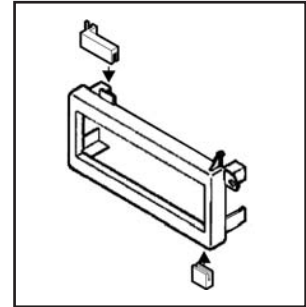

(Figure B)

Continue to kit assembly, p. 4.2

## DIN radio provision

1. Slide the DIN cage into the kit and secure by bending the metal locking tabs down.
2. Slide the aftermarket radio into the cage until secure. (Figure A)
3. Locate the factory wiring harness in the dash. Metra recommends using the proper mating adapter from Metra or AXCESS. Re-connect the negative battery terminal and test the unit for proper operation.
4. Reassemble dash in reverse order of disassembly. (Figure B)

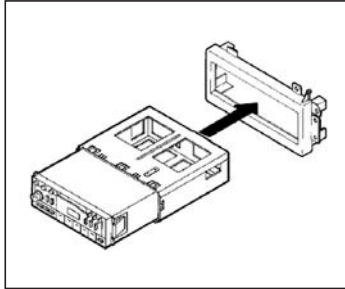

*(Figure A)*

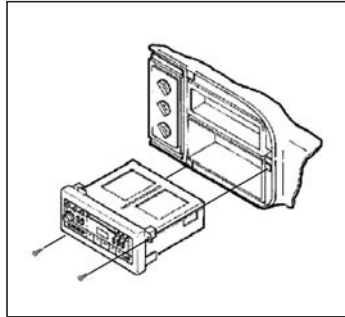

*(Figure B)*

## Notes

---

---

---

---

---

---

---

---

---

---

---

---

---

---

---

## Section 5

# Dodge/Eagle/Mitsubishi/ Plymouth 1985-1996 99-7000

### KIT FEATURES

- Pocket provisions

### KIT COMPONENTS

- A) Radio housing • B) Equalizer housing • C) Faceplate
- D) Bracket Set #1 • E) Bracket Set #2 • F) Filler bar
- G) Equalizer dummy plate • H) (6) #8 x 3/4" hex-head screws • I) (4) #8 x 1/2" hex-head screws

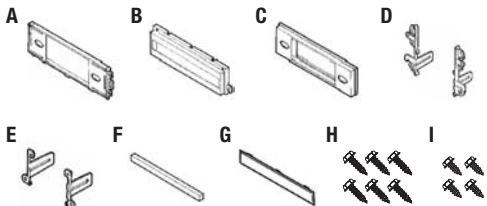

### TOOLS REQUIRED

- Phillips screwdriver • Cutting tool

## Applications

<b>Dodge</b>		<b>Eagle</b> <i>(continued)</i>		Mirage	1989-1992
Colt	1987-1988	Talon	1990-1994	Montero	1987-1991
Colt	1989-1992			Sigma	1989-1990
D-50 pick-up		<b>Mitsubishi</b>		Van	1987-1990
1987-1993		Eclipse	1990-1994		
Raider	1987-1991	Expo	1992-1995	<b>Plymouth</b>	
		Galant	1985-1988	Colt Vista	1992-1994
		Galant	1989-1993	Laser	1990-1994
<b>Eagle</b>		Mighty Max pick-up			
Summit	1989-1992		1987-1996		
Summit <i>(wagon)</i>			1985-1988		
1992-1996		Mirage			

## Table of Contents 99-7000

### Dash Disassembly

- Dodge Colt 1987-1988.....	5.0-5.1
- Dodge Colt 1989-1992.....	5.1
- Dodge D-50 pick-up 1987-1993.....	5.2
- Dodge Raider 1987-1991.....	5.2-5.3
- Eagle Summit 1989-1992.....	5.1
- Eagle Summit <i>(wagon)</i> 1992-1996.....	5.3
- Eagle Talon 1990-1994.....	5.4
- Mitsubishi Eclipse 1990-1994.....	5.4
- Mitsubishi Expo 1992-1995.....	5.3
- Mitsubishi Galant 1985-1988.....	5.4
- Mitsubishi Galant 1989-1993.....	5.5

## Table of Contents

- Mitsubishi Mighty Max pick-up 1987-1996.....	5.2
- Mitsubishi Mirage/Dodge Colt 1985-1988.....	5.0-5.1
- Mitsubishi Mirage/Dodges Colt 1989-1992.....	5.1
- Mitsubishi Montero 1987-1991.....	5.2-5.3
- Mitsubishi Sigma 1989-1990.....	5.4
- Mitsubishi Van 1987-1990.....	5.5
- Plymouth Colt Vista 1992-1994.....	5.3
- Plymouth Laser 1990-1994.....	5.4

### Kit Assembly

- 2-Shaft radio provision.....	5.6
- DIN radio provision.....	5.6

## Dodge Colt 1987-1988, Mitsubishi Mirage 1985-1988

1. Remove the ashtray and the (2) exposed screws.
2. Unclip the gear shifter trim bezel and remove the (4) exposed screws.
3. Pop off the hazard switch and remove the (1) exposed screw.

*Continue on next page*

### Dodge Colt 1987-1988, Mitsubishi Mirage 1985-1988

- Remove the dummy cap located below the brake lever and (2) exposed screws.
- Remove the screws securing the factory radio and disconnect the wiring. (Figure A)
- Snap the filler bar onto the equalizer housing and slide the assembly onto the bottom of the radio housing. (Figure B)
- Mount bracket Set #2 to the back of the equalizer housing with (4) #8 x 1/2" hex-head screws supplied. (Figure C)

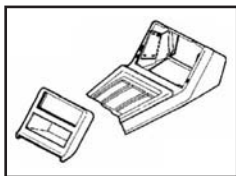

(Figure A)

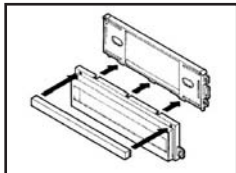

(Figure B)

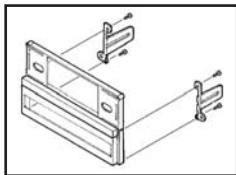

(Figure C)

### Dodge Colt/Eagle Summit/Mitsubishi Mirage 1989-1992

- Remove (2) Phillips screws above the climate controls.
- Remove (2) Phillips screws from the bottom edge of the radio trim bezel and remove the bezel.
- Remove (4) Phillips securing the factory radio and disconnect the wiring. (Figure A)
- Snap the filler bar onto the equalizer housing and slide the assembly onto the bottom of the radio housing. (Figure B)
- Cut and remove all mounting tabs on bracket Set #1 **EXCEPT** tabs "B". (Figure C)
- Mount the converted brackets to the back of the assembly with (6) #8 x 3/4" hex-head screws supplied.

*Note: The factory pocket may be used by omitting this step and mounting the pocket under the radio housing during installation.*

*Continue to kit assembly, p. 5.6*

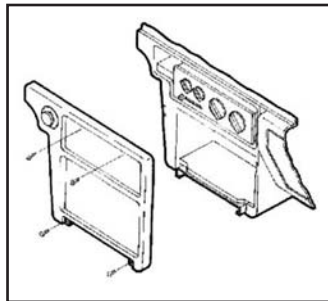

(Figure A)

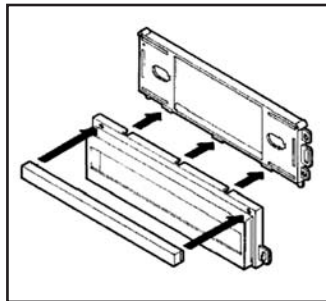

(Figure B)

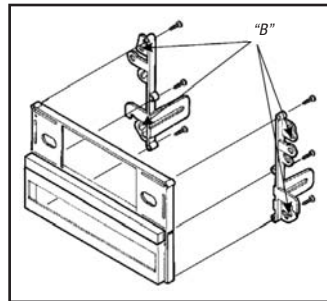

(Figure C)

*Mounting tab(s): identified by a stamped letter on back of tab*

### Dodge D-50 pick-up 1987-1993 Mitsubishi Mighty Max 1987-1996

1. Remove (2) screws located under the A/C vents. Remove the climate control knobs.
2. Remove (2) screws above the climate controls.
3. Using a small screwdriver, unclip the top of the dash trim bezel and remove the bezel.
4. Remove (4) Phillips screws securing the factory radio and disconnect the wiring. (Figure A)
5. Snap the filler bar onto the equalizer housing and slide the assembly onto the bottom of the radio housing. (Figure B)

**Note:** The factory pocket may be used by omitting this step and mounting the pocket under the radio housing during installation.

6. Cut and remove all mounting

tabs on bracket Set #1 **EXCEPT** tabs "F". (Figure C)

7. Mount the converted brackets to the back of the assembly with (6) #8 x 3/4" hex-head screws supplied.

*Continue to kit assembly, p. 5.6*

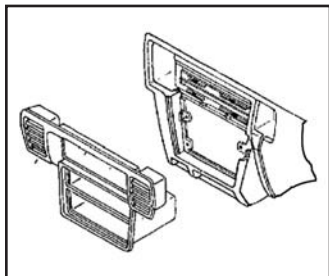

(Figure A)

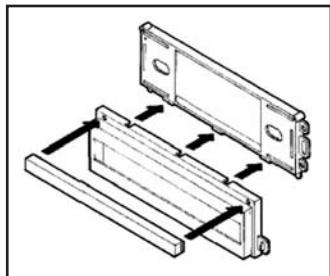

(Figure B)

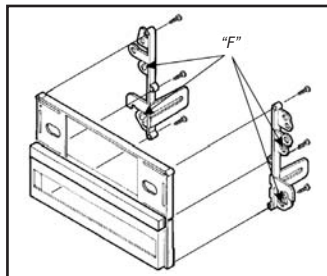

(Figure C)

*Mounting tab(s): identified by a stamped letter on back of tab*

### Dodge Raider/Mitsubishi Montero 1987-1991

1. Remove the climate control knobs and then remove the (2) screws above the climate controls.
2. Pop off the cover caps from the sides of the dash console and remove the (4) exposed screws.
3. Remove (4) screws from the gear shifter plate and remove the plate.
4. Pull the dash console assembly forward and disconnect the wiring.
5. Remove (4) screws securing the radio trim bezel to the console and remove.
6. Remove (4) screws securing the factory radio and disconnect the wiring. (Figure A)

*Continue on next page*

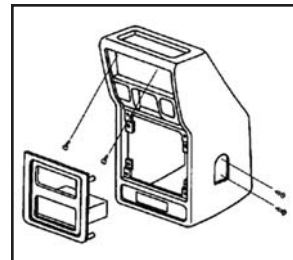

(Figure A)

## Dodge Raider/Mitsubishi Montero 1987-1991

7. Snap the filler bar onto the equalizer housing and slide the assembly onto the bottom of the radio housing. (Figure B)

*Note: The factory pocket may be used by omitting this step and mounting the pocket under the radio housing during installation.*

8. Cut and remove all mounting tabs on bracket Set #1 **EXCEPT** tabs "B". (Figure C)
9. Mount the converted brackets to the back of the assembly with (6) #8 x 3/4" hex-head screws supplied.

*Continue to kit assembly, p. 5.6*

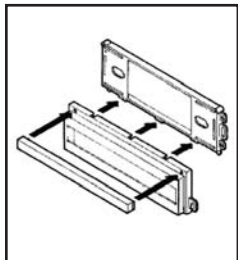

(Figure B)

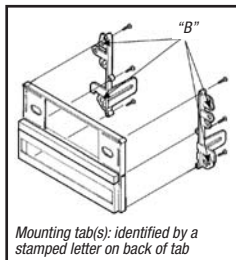

*Mounting tab(s): identified by a stamped letter on back of tab*

(Figure C)

## Eagle Summit (wagon) 1992-1996, Mitsubishi Expo 1992-1995, Plymouth Colt Vista 1992-1994

1. Remove (2) screws from the top of the radio trim bezel.
2. Remove the ashtray and the (2) exposed screws.
3. Unclip the radio trim bezel and disconnect the cigarette lighter wiring.
4. Remove the screws securing the factory radio and disconnect the wiring. (Figure A)
5. Snap the filler bar onto the equalizer housing and slide the assembly onto the bottom of the radio housing. (Figure B)
6. Cut and remove all mounting tabs on the radio housing **EXCEPT** tabs "D". (Figure C)

*Continue to kit assembly, p. 5.6*

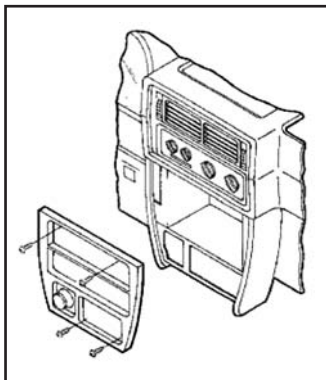

(Figure A)

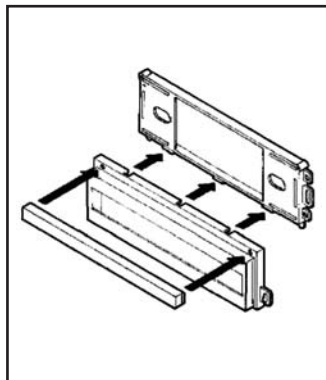

(Figure B)

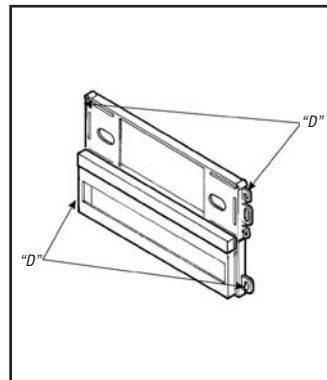

(Figure C)

*Mounting tab(s): identified by a stamped letter on back of tab*



### Eagle Talon/Mitsubishi Eclipse/Plymouth Laser 1990-1994

1. Unclip the radio trim bezel and remove.
2. Remove (4) Phillips securing the factory radio and disconnect the wiring. (Figure A)
3. Snap the filler bar onto the equalizer housing and slide the assembly onto the bottom of the radio housing. (Figure B)
4. Cut and remove all mounting tabs on the Radio Housing **EXCEPT** tabs "D". (Figure C)

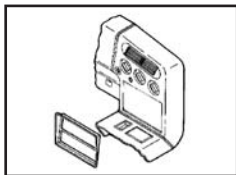

(Figure A)

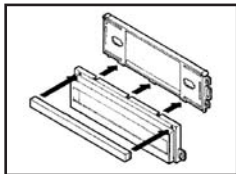

(Figure B)

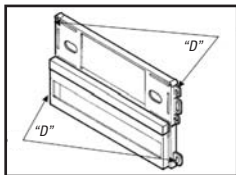

(Figure C) Mounting tab(s): identified by a stamped letter on back of tab

Continue to kit assembly, p. 5.6

### Mitsubishi Galant 1985-1988 Mitsubishi Sigma 1989-1990

1. Unclip the radio trim bezel and remove.
2. Remove (4) screws securing the factory radio and disconnect the wiring. (Figure A)
3. Snap the filler bar onto the equalizer housing and slide the assembly onto the bottom of the radio housing. (Figure B)
4. Cut and remove all mounting tabs on bracket Set #1 **EXCEPT** tabs "H".
5. Mount the converted brackets to the back of the assembly with (6) #8 x 3/4" hex-head screws supplied. (Figure C)

Continue to kit assembly, p. 5.6

**Note:** The factory pocket may be used by omitting this step and mounting the pocket under the Radio Housing during installation.

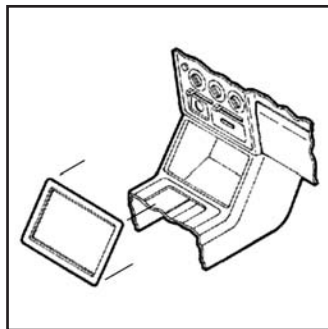

(Figure A)

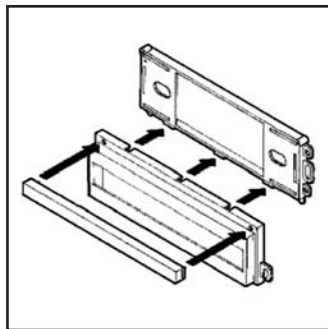

(Figure B)

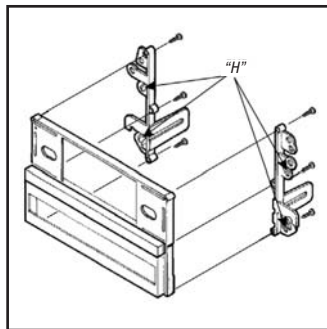

(Figure C)

Mounting tab(s): identified by a stamped letter on back of tab

### Mitsubishi Galant 1989-1993

1. Unclip the radio trim bezel and remove.
2. Remove (4) screws securing the factory radio and disconnect the wiring. (Figure A)
3. Snap the filler bar onto the equalizer housing and slide the assembly onto the bottom of the radio housing. (Figure B)
4. Cut and remove all mounting tabs on the radio housing **EXCEPT** tabs "G". (Figure C)

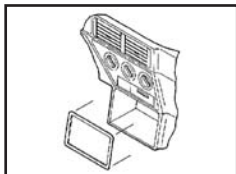

(Figure A)

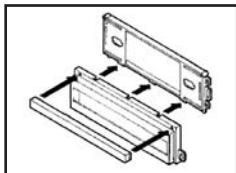

(Figure B)

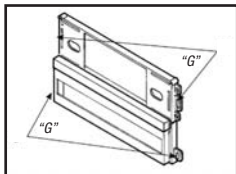

(Figure C) Mounting tab(s): identified by a stamped letter on back of tab

Continue to kit assembly, p. 5.6

### Mitsubishi Van 1987-1990

1. Remove (3) screws from the bottom edge of the dash trim bezel and remove the bezel.
2. Remove (4) screws securing the factory radio and disconnect the wiring. (Figure A)
3. Snap the filler bar onto the equalizer housing and slide the assembly onto the bottom of the radio housing. (Figure B)

**Note:** The factory pocket may be used by omitting

*this step and mounting the pocket under the radio housing during installation.*

4. Cut and remove all mounting tabs on bracket Set #1 **EXCEPT** tabs "H".
5. Mount the converted brackets to the back of the assembly with (6) #8 x 3/4" hex-head screws supplied.

Continue to kit assembly, p. 5.6

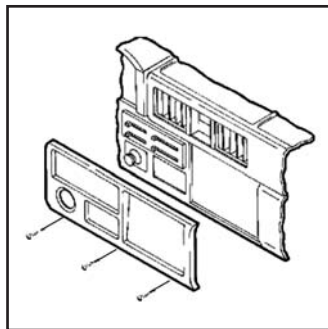

(Figure A)

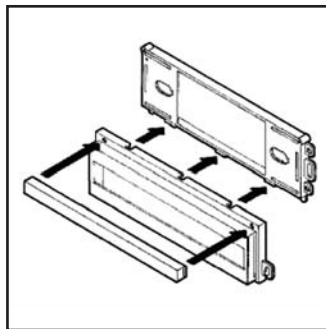

(Figure B)

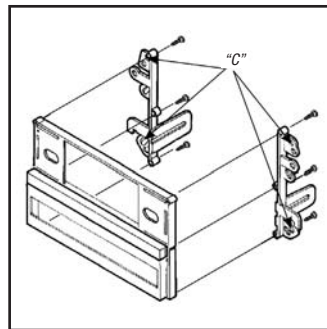

(Figure C)

Mounting tab(s): identified by a stamped letter on back of tab

## 2-Shaft radio provision

1. Attach the faceplate to radio housing.
2. Slide the aftermarket radio into the kit and secure with shaft nuts. (Figure A)
3. Locate the factory wiring harness in the dash. Metra recommends using the proper mating adapter from Metra or AXCESS. Re-connect the negative battery terminal and test the unit for proper operation.
4. Reassemble dash in reverse order of disassembly.

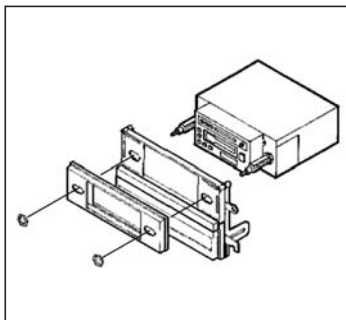

(Figure A)

## DIN radio provision

1. Cut and remove the shaft supports.
2. Slide the DIN cage into the radio housing and secure by bending the metal locking tabs down.
3. Slide the aftermarket radio into the cage until secure. (Figure A)

**Note:** If an equalizer will be included, slide the unit into the back of the radio housing and secure. If an equalizer will NOT be included, snap the equalizer dummy plate into the opening.

4. Locate the factory wiring harness in the dash. Metra recommends using the proper mating adapter from Metra or AXCESS. Re-connect the negative battery terminal and test the unit for proper operation.
5. Reassemble dash in reverse order of disassembly. (Figure B)

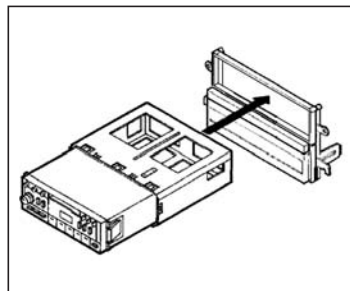

(Figure A)

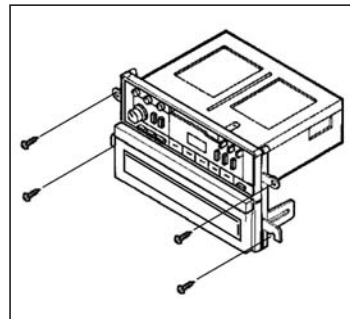

(Figure B)



## Dash Disassembly INST-6000

### Section 6

#### 99-6000, 99-6500, 99-6501

Chrysler/Dodge/Eagle/Ford/Jeep/Lincoln  
Mercury/Plymouth

### Various Dash Disassemblies

*INST-6000 is a collection of installation instruction booklets.  
Use the Application Overview when selecting which  
installation instruction selection to use. Each section is setup  
as a chapter with its own table of contents.*

#### Dash Disassembly

- Chrysler Cirrus/Dodge Stratus 1995-2000,  
Plymouth Breeze 1996-1999 ..... 6.1
- Chrysler Concorde/LHS 1995-1998, Dodge  
Intrepid/Eagle Vision 1993-1997 ..... 6.1
- Chrysler Cordoba/Plymouth Fury  
1975-1978, Dodge Charger 1974-1978,  
Magnum XE 1978-1979..... 6.1
- Chrysler Cordoba 1979-1983/Imperial  
1982-1983/Newport 1980-1981,  
Dodge Mirada 1980-1983/  
St. Regis 1979-1981 ..... 6.1
- Chrysler E-Class 1983-1984/LeBaron  
1982-1985/New Yorker 1983-1987, Dodge  
Aries 1981-1989/400 1982-1983/600  
1983-1987, Plymouth Caravelle  
1985-1987/Reliant 1981-1989 ..... 6.2
- Chrysler 5th Avenue/Imperial 1990-1994/  
New Yorker 1988-1995, Dodge  
Dynasty 1988-1993..... 6.2
- Chrysler Laser/Dodge  
Daytona 1984-1989..... 6.2
- Chrysler Laser/Dodge  
Daytona 1984-1989..... 6.2
- Chrysler LeBaron 1984-1995 ..... 6.2
- Chrysler LeBaron GTS 1985-1994,  
Dodge Lancer 1985-1989 ..... 6.3

### Table of Contents

- Chrysler LeBaron 1976-1981, Dodge  
Diplomat 1976-1989/Aspen 1976-1980,  
Plymouth Gran Fury 1975-1985/  
Volare 1976-1980..... 6.3
- Chrysler Sebring/Dodge  
Avenger 1995-2000..... 6.3
- Chrysler Sebring (convertible)  
1995-2000 ..... 6.3
- Chrysler Town & Country 1990-1995,  
Dodge Caravan/Plymouth  
Voyager 1984-1990 ..... 6.4
- Dodge Caravan/Plymouth  
Voyager 1991-1995..... 6.4
- Dodge Caravan/Chrysler Town & Country/  
Plymouth Voyager 1996-2000..... 6.4
- Dodge Caravan/Chrysler Town & Country/  
Plymouth Voyager 1996-2000..... 6.4
- Dodge Charger/Plymouth  
Turismo 1983-1987 ..... 6.4
- Dodge Dakota 1987-1996 ..... 6.5
- Dodge Dakota 1997-2000 ..... 6.5
- Dodge Daytona 1990-1993 ..... 6.5
- Dodge Durango 1997-2000..... 6.5
- Dodge Neon/Plymouth Neon 1994-1999 .. 6.5
- Dodge Omni/024/Rampage 1978-1982,  
Plymouth Horizon/TC3 1978-1982/  
Scamp 1983-1984..... 6.6
- Dodge Pickup/Ramcharger 1974-1980,  
Plymouth Trailduster 1974-1980 ..... 6.6
- Dodge Pickup/Ramcharger 1974-1980,  
Plymouth Trailduster 1974-1980 ..... 6.6
- Dodge Pickup/Ramcharger 1981-1993,  
Plymouth Trailduster 1981 ..... 6.6
- Dodge Ram 1994-2001,  
Ram 2500/3500 2002..... 6.6
- Dodge Shadow/Plymouth  
Sundance 1987-1994 ..... 6.7
- Dodge Spirit/Plymouth  
Acclaim 1989-1995 ..... 6.7
- Dodge Van/Plymouth Van 1978-2003 ..... 6.7
- Ford Aerostar 1985-1991 ..... 6.7
- Ford Bronco II/  
Ranger (mini) 1985-1988..... 6.7
- Ford Crown Victoria/LTD 1979-1990,  
Mercury Grand Marquis/  
Marquis 1979-1990 ..... 6.7
- Ford Thunderbird/Mercury  
Cougar 1985-1988 ..... 6.8
- Jeep Cherokee 1997-2001..... 6.8
- Jeep Grand Cherokee 1993-1995 ..... 6.8
- Jeep Grand Cherokee 1996-1998 ..... 6.8
- Jeep Wrangler 1997-2002 ..... 6.8
- Lincoln Continental 1985-1987 ..... 6.9
- Lincoln Mark VII 1984-1989 ..... 6.9

### **Chrysler Cirrus/Dodge Stratus 1995-2000, Plymouth Breeze 1996-1999**

1. Using a flat-blade screwdriver, pry out on the edges of the radio trim bezel.
2. Unclip the bezel and remove.
3. Remove (2) 3/8" hex-head screws securing the factory radio and disconnect the wiring.

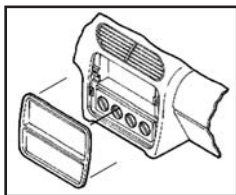

### **Chrysler Cordoba/ Plymouth Fury 1975-1978, Dodge Charger 1974-1978, Magnum XE 1978-1979**

1. Remove (4) Phillips screws from the bottom edge of the radio trim bezel.
2. Remove (2) Phillips screws above the radio opening. (Figure A)
3. Unscrew the retainer ring securing the remote mirror control and remove the bezel.
4. Remove (2) 3/8" hex-head screws securing the factory radio and disconnect the wiring.

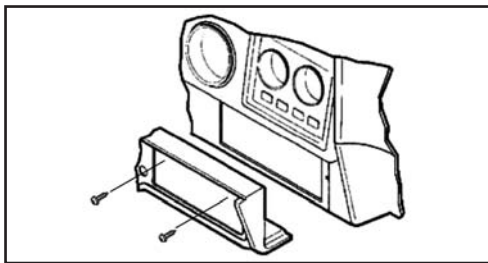

### **Chrysler Cordoba 1979-1983/Imperial 1982-1983/ Newport 1980-1981/New Yorker 1980-1981, Dodge Mirada 1980-1983/St. Regis 1979-1981**

1. Remove (2) Phillips screws above the radio opening. (Figure A)
2. Remove (2) Phillips screws above the climate controls. (Figure A)
3. Unclip the dash trim bezel and remove.
4. Remove (2) 3/8" hex-head screws securing the factory radio and disconnect the wiring.

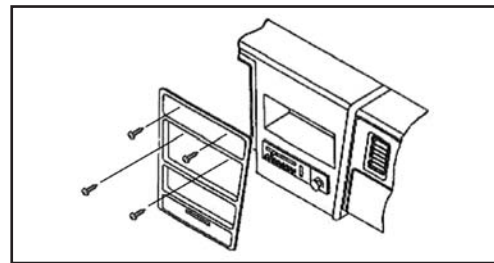

### **Chrysler Concorde/LHS 1995-1998, Dodge Intrepid/ Eagle Vision 1993-1997**

1. Unclip the radio trim bezel and remove.
2. Remove (2) 3/8" hex-head screws securing the factory radio and disconnect the wiring.

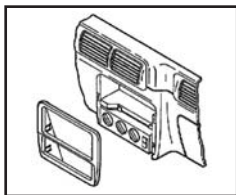

**Chrysler E-Class 1983-1984/  
LeBaron 1982-1985/New  
Yorker 1983-1987  
Dodge Aries 1981-1989/400  
1982-1983/600 1983-1987  
Plymouth Caravelle 1985-  
1987/Reliant 1981-1989**

1. Remove (3) Phillips screws from the top edge of the dash trim bezel.
2. Remove (3) Phillips screws from the bottom edge of the dash trim bezel.
3. Unclip the bezel and disconnect the wiring.
4. Remove (2) 3/8" hex-head bolts securing the factory radio and disconnect the wiring.

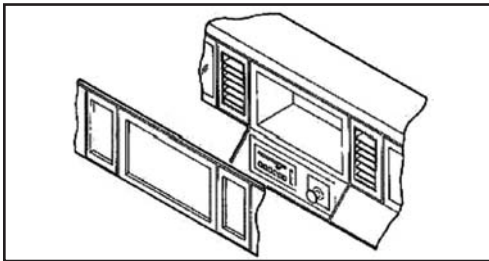

**Chrysler 5th Avenue/  
Imperial 1990-1994/New  
Yorker 1988-1995, Dodge  
Dynasty 1988-1993**

1. Remove (2) Phillips screws above the radio opening.
2. Remove (2) Phillips screws above the climate controls.
3. Unclip the dash trim bezel and remove.
4. Remove (2) 3/8" hex-head screws securing the factory radio and disconnect the wiring.

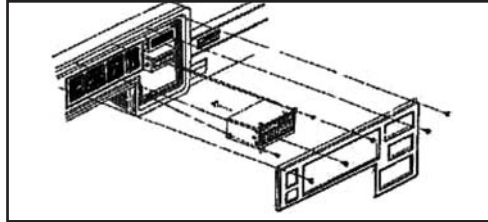

**Chrysler Laser/Dodge  
Daytona 1984-1989**

1. Remove (2) Phillips screws from the base of the dash trim bezel.

**Chrysler Laser/Dodge  
Daytona 1984-1989**

2. Pull out on the lower edge of the bezel and remove.
3. Remove (2) 3/8" hex-head screws securing the factory radio and disconnect the wiring.

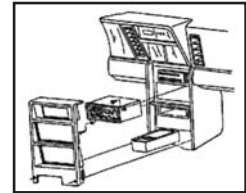

**Chrysler LeBaron 1984-1995**

1. Remove (1) Phillips screw from the lower corner of the dash trim bezel.
2. Unclip the bezel and remove.
3. Remove (2) Phillips screws from the right console panel and remove the panel.
4. Remove (2) hex-head screws securing the factory radio and disconnect the wiring.

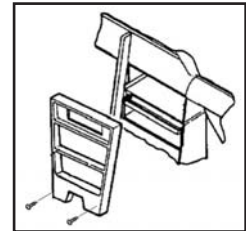

### **Chrysler LeBaron GT5 1985-1994, Dodge Lancer 1985-1989**

1. Remove (5) torx-head screws from the top of the dash trim bezel.
2. Remove (2) torx-head screws below the radio opening.
3. Remove (1) torx-head screw from the upper-left corner of the radio opening.
4. Remove (4) torx-head screws from the lower-left area of the dash trim bezel.
5. Unclip the bezel and remove.
6. Remove (2) 3/8" hex-head bolts securing the factory radio and disconnect the wiring.

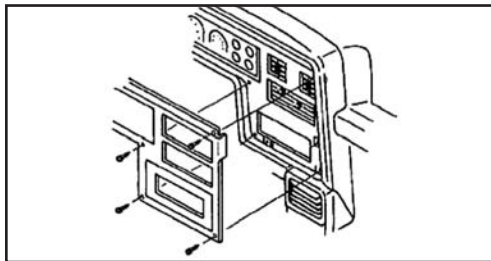

### **Chrysler LeBaron 1976- 1981, Dodge Diplomat 1976-1989/Aspen 1976-1980, Plymouth Gran Fury 1975-1985/Volare 1976-1980**

1. Remove (4) Phillips screws from the top of the dash trim bezel.
2. Remove (4) Phillips screws from the bottom of the dash trim bezel.
3. Remove (2) 3/8" hex-head screws securing the factory radio and disconnect the wiring.

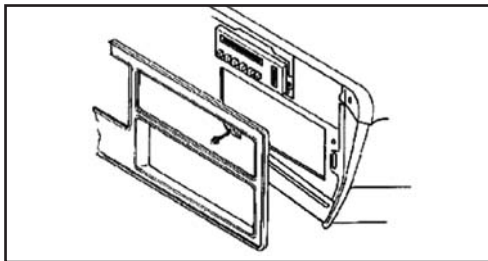

### **Chrysler Sebring/Dodge Avenger 1995-2000**

1. Unclip the radio trim bezel and remove.
2. Remove (2) #10 Phillips screws securing the factory radio and disconnect the wiring.

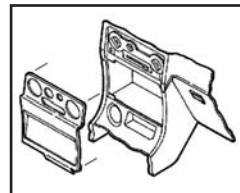

### **Chrysler Sebring (convertible) 1995-2000**

1. Unclip the radio trim bezel and remove.
2. Remove (2) 3/8" hex-head screws securing the factory radio and disconnect the wiring.

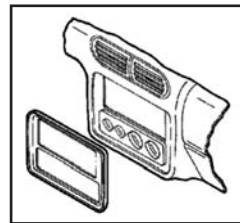

### **Chrysler Town & Country 1990-1995, Dodge Caravan/Plymouth Voyager 1984-1990**

1. Reach behind the ashtray and release the rear tab on the ashtray housing.
2. Remove (2) screws from the bottom edge of the dash trim bezel.
3. Remove (3) screws from the top edge of the dash trim bezel.
4. Unsnap the left edge of the bezel and remove.
5. Remove (2) 3/8" hex-head screws securing the factory radio and disconnect the wiring.

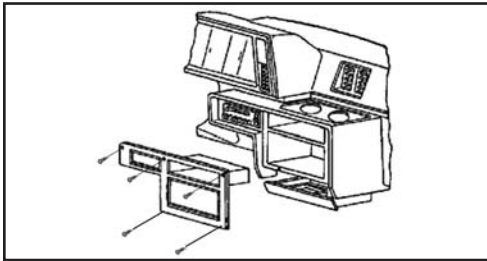

### **Dodge Caravan/Plymouth Voyager 1991-1995**

1. Remove the cigarette lighter.
2. Using a panel removal tool, pry out on the dash trim bezel and remove.
3. Remove (2) 3/8" bolts securing the factory radio and disconnect the wiring.

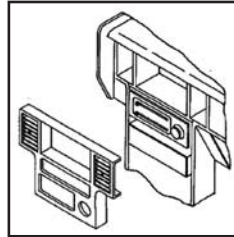

### **Dodge Caravan/Chrysler Town & Country/Plymouth Voyager 1996-2000**

3. Unclip the dash trim bezel, disconnect the climate control wiring and remove the bezel.
4. Remove (2) 3/8" hex-head screws securing the factory radio and disconnect the wiring.

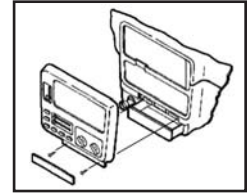

### **Dodge Caravan/Chrysler Town & Country/Plymouth Voyager 1996-2000**

1. Pull the ashtray forward. Unsnap the plastic trim piece located below the radio trim bezel and remove (2) Phillips screws exposed.
2. Remove (2) Phillips screws above the radio opening.

### **Dodge Charger/Plymouth Turismo 1983-1987**

1. Unclip the radio trim bezel and remove. (Figure A)
2. Remove (2) 3/8" hex-head screws securing the factory radio and disconnect the wiring.

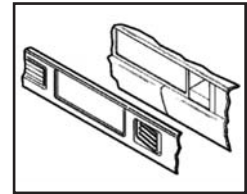



### **Dodge Dakota 1987-1996**

1. Remove (8) torx-head screws from the dash trim bezel.
2. Remove (2) Phillips screws from the lower steering column trim and remove.
3. Remove (1) Phillips screw from each side of the steering column.
4. Unclip the dash trim bezel and remove. (Figure A)
5. Remove (2) Phillips screws securing the factory radio and disconnect the wiring.

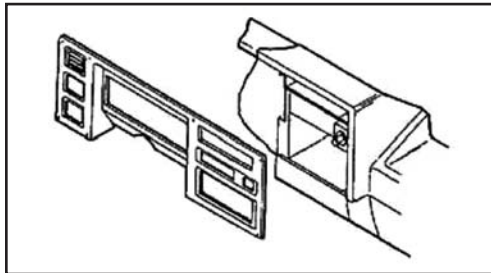

### **Dodge Dakota 1997-2000**

1. Unclip the entire dash trim bezel. (Figure A)
2. Remove (2) 3/8" hex-head screws securing the factory radio and disconnect the wiring.

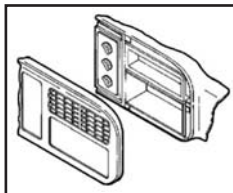

### **Dodge Durango 1997-2000**

1. Unclip the entire dash trim bezel. (Figure A)
2. Remove (2) 3/8" hex-head screws securing the factory radio and disconnect the wiring.

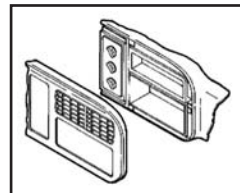

### **Dodge Daytona 1990-1993**

1. Pull out on the dash trim bezel and remove. (Figure A)
2. Remove (2) screws from each side of the lower console (this will allow easier radio removal).
3. Remove (2) screws securing the factory radio and disconnect the wiring.

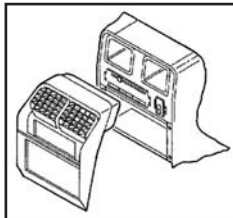

### **Dodge Neon/Plymouth Neon 1994-1999**

1. Remove the ashtray.
2. Unclip the radio trim bezel and remove. (Figure A)
3. Remove (2) 3/8" hex-head screws securing the factory radio and disconnect the wiring.

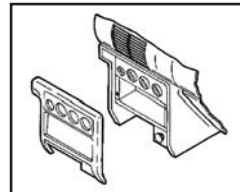

### Dodge Omni/024/Rampage 1978-1982, Plymouth Horizon/TC3 1978-1982/ Scamp 1983-1984

1. Remove (7) Phillips screws from the dash trim bezel and remove the bezel.
2. Remove (2) 3/8" hex-head screws securing the factory radio and disconnect the wiring.

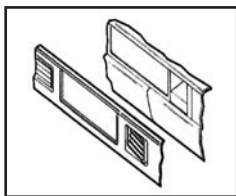

### Dodge Pickup/Ramcharger 1974-1980, Plymouth Trailduster 1974-1980

1. Remove (4) Phillips screws from the top edge of the dash trim bezel.
2. Remove (7) Phillips screws from the face of the dash trim bezel.
3. Remove (3) Phillips screws under the dash trim bezel.

### Dodge Pickup/Ramcharger 1974-1980, Plymouth Trailduster 1974-1980

4. Unclip the bezel and remove. (Figure A)
5. Remove (2) 3/8" hex-head screws securing the factory radio and disconnect the wiring.

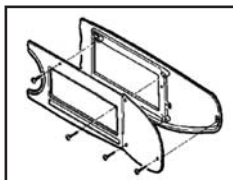

### Dodge Pickup/Ramcharger 1981-1993, Plymouth Trailduster 1981

1. Remove (5) Phillips screws from the edge of the dash trim bezel.
2. Remove (1) Phillips screw above the radio opening.
3. Pry out on the bottom edge of the bezel and remove.
4. Remove (2) 3/8" hex-head screws

securing the factory radio and disconnect the wiring.

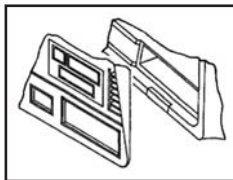

### Dodge Ram 1994-2001, Ram 2500/3500 2002

1. Remove the ashtray. Remove (2) Phillips screws exposed in the ashtray cavity and remove the ashtray bracket. Remove the cupholder.
2. Remove (2) Phillips screws exposed in the cupholder cavity and remove the cupholder bracket.
3. Unclip the dash trim bezel, pull the bezel over the steering column and remove.
4. Remove (2) 3/8" hex-head screws securing the factory radio and disconnect the wiring.

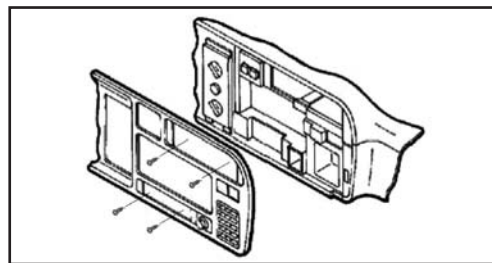

### Dodge Shadow/Plymouth Sundance 1987-1994

1. Remove the ashtray. Unclip the dash trim bezel and remove.
2. Remove (1) Phillips screw from the console side trim and remove.
3. Remove (2) 3/8" hex-head bolts securing the factory radio and disconnect the wiring.

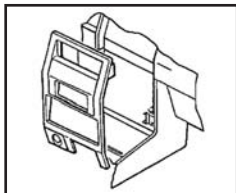

### Dodge Spirit/Plymouth Acclaim 1989-1995

1. Unclip the dash trim bezel and remove.
2. Remove the screws securing the side console trim pieces.
3. Pull the right trim piece out and remove (1) hex-head bolt exposed.
4. Remove (1) hex-head bolt securing the bottom-left corner of the factory radio and disconnect the wiring.

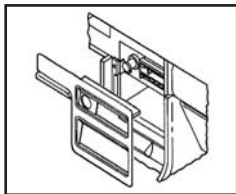

### Dodge Van/Plymouth Van 1978-2003

1. Open the glove box and remove (2) Phillips screws exposed.
2. Remove (5) Phillips screws from the bottom of the dash trim bezel.
3. Unclip the top edge of the bezel and remove.
4. Remove (2) 3/8" hex-head screws securing the factory radio and disconnect the wiring.

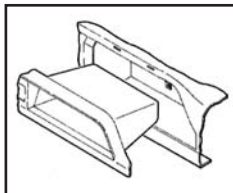

### Ford Aerostar 1985-1991

1. Remove (2) Phillips screws from the base of the dash panel.
2. Pry down on the (2) tabs located at the top of the radio trim bezel and remove the bezel.
3. Remove (4) screws securing the factory radio and disconnect the wiring.

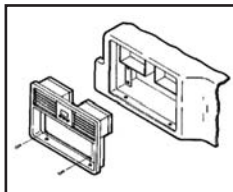

### Ford Bronco II/Ranger (mini) 1985-1988

1. Remove (4) Phillips screws from the top edge of the dash trim bezel.
2. Remove the light switch knob, cigarette lighter and ashtray.
3. Unsnap the molding under the dash trim bezel and remove (4) screws exposed. Remove (4) screws securing the factory radio and disconnect the wiring.

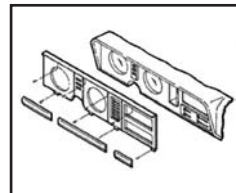

### Ford Crown Victoria/LTD 1979-1990, Mercury Grand Marquis/Marquis 1979-1990

1. Open the ashtray and remove (2) Phillips screws exposed.
2. Remove the dash trim bezel.
3. Remove (4) screws securing the factory radio and disconnect the wiring.

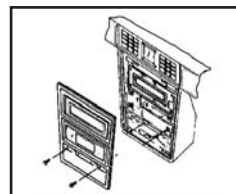

**Ford Thunderbird/Mercury Cougar 1985-1988**

1. Remove (2) screws from the top of the dash trim bezel.
2. Open the ashtray and remove (2) screws exposed in the ashtray cavity.
3. Remove the dash trim bezel. Remove (4) screws securing the factory radio and disconnect the wiring.

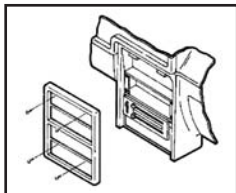
**Jeep Cherokee 1997-2001**

1. Unclip the dash trim bezel.
2. Remove (2) #10 hex-head screws securing the factory radio and disconnect the wiring.

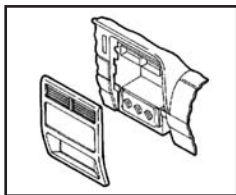
**Jeep Grand Cherokee 1993-1995**

1. Remove (2) Phillips screws from the bottom of the dash trim bezel.
2. Remove (2) Phillips screws above the radio opening.
3. Remove (2) Phillips screws to the left of the steering column.
4. Remove (1) Phillips screw to the right of the steering column.
5. Unclip the dash trim bezel and disconnect the wiring.

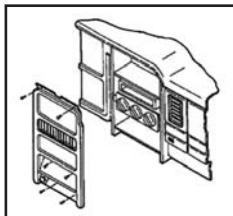
**Jeep Grand Cherokee 1996-1998**

1. Unsnap the climate control/wiper control trim panel and remove.
2. Remove (5) Phillips screws from the top of the radio/instrument cluster trim bezel.
3. Remove (4) Phillips screws from the bottom of the radio/instrument cluster trim bezel.

**Jeep Grand Cherokee 1996-1998**

4. Pry out on the bottom edge of the bezel and remove. (Figure A)
5. Remove (2) 3/8" hex-head screws securing the factory radio and disconnect the wiring.

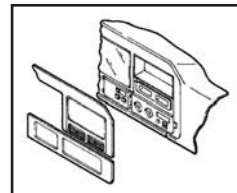
**Jeep Wrangler 1997-2002**

1. Remove the ashtray and (1) Phillips screw exposed in the ashtray cavity. (Figure A)
2. Pry out on the top cover of the instrument panel and remove (2) Phillips screws exposed.
3. Pry out on the bottom edge of the dash trim bezel and remove.
4. Remove (2) 3/8" hex-head screws securing the factory radio and disconnect the wiring.

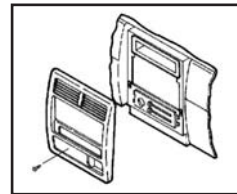

### Lincoln Continental 1985-1987

1. Remove (2) #8 Phillips screws below the radio opening.
2. Open the ashtray and remove (2) #8 Phillips screws (it is NOT necessary to remove the center screw).
3. Unclip the dash trim bezel and remove.
4. Remove (4) hex-head screws securing the factory radio and disconnect the wiring.

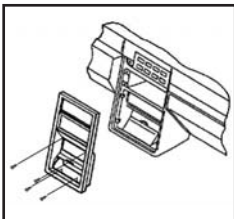

### Notes

---

---

---

---

---

---

---

---

---

---

---

---

---

---

---

---

---

---

---

---

---

---

---

---

### Lincoln Mark VII 1984-1989

1. Pry out on the dash trim bezel and remove. (Figure A)
2. Remove (4) 5mm hex-head sheet metal screws securing the factory radio and disconnect the wiring.

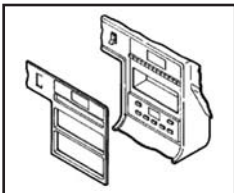







## INSTALLATION INSTRUCTIONS FOR PART INST-6000



REV. 9/3/2014 INST-6000



### KNOWLEDGE IS POWER

Enhance your installation and fabrication skills by enrolling in the most recognized and respected mobile electronics school in our industry. Log onto [www.installerinstitute.com](http://www.installerinstitute.com) or call 800-354-6782 for more information and take steps toward a better tomorrow.



**Metra recommends MECP  
certified technicians**





## INSTRUCCIONES DE INSTALACIÓN PARA LA PIEZA INST-6000

### APLICACIONES

# Chrysler/Ford/Mitsubishi 1974-2003\* INST-6000

## INSTRUCCIONES DE INSTALACIÓN

---

- 99-6000 • 99-6501 • 99-7000
- 99-6500 • 99-6700

*\* Vehículos que aplican dentro del rango de años indicado. Consulte cada sección de aplicación para ver instrucciones específicas para el modelo y año(s).*

## HERRAMIENTAS REQUERIDAS

---

*Consulte la página de cada título de sección.*

*INST-6000 es una colección de instructivos de instalación. Utilice la Información general sobre aplicación al seleccionar cuáles instrucciones de instalación utilizar. Cada sección está configurada como un capítulo con su propio índice.*

## Aplicación General

### 99-6000

Chrysler/Dodge/Eagle/Jeep/  
Plymouth 1974-2003\*\*

### 99-6500

Chrysler/Dodge/Eagle/Ford/  
Jeep/Lincoln/Mercury/  
Plymouth 1974-2003\*\*

### 99-6501

Chrysler/Dodge/Eagle/Jeep/  
Lincoln/Mercury/Plymouth  
1974-2003\*\*

### 99-6700

Crysler/Eagle/Ford/  
Jeep 1974-2003\*\*

### 99-7000

Dodge/Eagle/Mitsubishi/  
Plymouth 1985-1996\*\*

*\*\* Vehículos que aplican dentro del rango de años indicado. Consulte cada sección de aplicación para ver instrucciones específicas para el modelo y año(s).*

---

**PRECAUCIÓN:** *Metra recomienda desconectar el terminal negativo de la batería antes de comenzar cualquier instalación. Todos los accesorios, interruptores y, especialmente, las luces indicadoras de airbag deben estar enchufados antes de volver a conectar la batería a comenzar el ciclo de ignición.*

**NOTA:** *Remítase a las instrucciones incluidas con el radio de postventa.*

## Contenidos

<b>Instrucciones de instalación</b>	<b>Sección</b>
- 99-6000** .....	1.0
- 99-6500** .....	2.0
- 99-6501** .....	3.0
- 99-6700** .....	4.0
- 99-7000** .....	5.0
- Desensambles del tablero .....	6.0
<i>(99-6000, 99-6500, 99-6501, 99-6700)</i>	

## Sección 1

# Chrysler/Dodge/Jeep/ Plymouth 1974-2003 99-6000

### CARACTERÍSTICAS DEL KIT

- Provisión con bolsillo

### COMPONENTES DEL KIT

- A) Alojamiento del radio

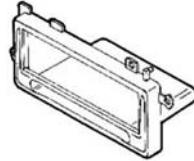
**A**

### HERRAMIENTAS REQUERIDAS

- Destornillador Phillips
- Herramienta de remoción de panel
- Herramienta de corte

## Aplicaciones

<b>Chrysler</b>	<b>Dodge</b> <i>(seguido)</i>	<b>Jeep</b>
Cirrus 1995-2000	Lancer 1986-1989	Cherokee 1997-2001
Concorde 1993-1997	Magnum XE	Grand Cherokee
Cordoba 1975-1983	1978-1997	1993-1995
E-Class 1983-1993	Mirada 1979-1989	Grand Cherokee
5th Avenue	Neon 1995-1999	1996-1998
1979-1993	Omni 1978-1990	Wrangler 1997-2002
Imperial 1982-1983	Pick-up 1974-1983	
Imperial 1990-1993	Ram 1994-2001	<b>Plymouth</b>
Laser 1984-1989	Ramcharger	Acclaim 1989-1995
LeBaron 1977-1995	1974-1993	Breeze 1996-1999
LeBaron GTS	Rampage 1978-1982	Caravelle 1985-1987
1985-1995	Shadow 1987-1995	Fury 1975-1978
LHS 1993-1998	Spirit 1989-1995	Gran Fury 1978-1989
Newport 1977-1981	St. Regis 1979-1981	Horizon 1978-1983
New Yorker	Stratus 1995-1999	Neon 1994-1999
1995-1996	Van 1978-2003	Reliant 1981-1989
Sebring 1975-2000	024 1978-1982	Scamp 1983-1984
Sebring <i>(conv)</i>	400 1982-1983	Sundance 1987-1994
1996-1999	600 1983-1987	TC3 1978-1982
Town & Country		Trailduster
1990-2000	<b>Ford</b>	1975-1981
	Aerostar 1985-1991	Turismo 1983-1987
<b>Dodge</b>	Bronco II 1983-1988	Van 1978-1997
Aries 1981-1989	Country Squire	Volare 1976-1980
Aspen 1976-1980	1979-1989	Voyager 1984-2000
Avenger 1995-2000	Crown Victoria	
Caravan 1984-2000	1983-1989	<b>Mitsubishi</b>
Charger 1974-1978	LTD 1979-1986	Galant 1989-1993
Charger 1981-1987	Ranger <i>(mini)</i>	Galant 1985-1988
Dakota 1987-2000	1983-1988	Sigma 1989-1990
Daytona 1984-1993	Thunderbird	Van 1987-1990
Diplomat 1976-1989	1980-1988	
Durango 1998-2000	<b>Eagle</b>	
Dynasty 1988-1993	Vision 1993-1997	
Intrepid 1993-1997		

\*\*INST-6000 es una colección de instructivos de instalación. Utilice la Información general sobre aplicación al seleccionar cuáles instrucciones de instalación utilizar. Cada sección está configurada como un capítulo con su propio índice.

## Índice 99-6000

### Preparación del kit

– Chrysler/Dodge/Eagle/Jeep/Plymouth** .....	1.1
<i>(Excepto: Grand Cherokee 1993-1995, Cirrus, Stratus, Sebring, Sebring descapotable, y Avenger)</i>	
– Chrysler Cirrus 1995-2000** .....	1.1
– Chrysler Sebring (descapotable) 1996-2000** .....	1.1
– Chrysler Sebring 1995-2000** .....	1.2
– Dodge Avenger 1995-2000** .....	1.2
– Dodge Stratus 1995-1999** .....	1.1
– Jeep Grand Cherokee 1993-1995** .....	1.2
– Plymouth Breeze 1996-1999** .....	1.1

### Ensamble del kit

– Provisión de radio DIN.....	1.2
-------------------------------	-----

**\*\*ATENCIÓN:** Consulte en la Sección 6 el desensamble del tablero.

**Atención:** Este kit (99-6000) ha sido especialmente diseñado con las costillas de apoyo para asegurar la integridad estructural durante el transporte. Por favor corte y eliminar estas costillas de la apertura del radio antes de comenzar la instalación.

## Chrysler/Dodge/Eagle/ Jeep/Plymouth

*(Excepto: Grand Cherokee 1993-1995, Cirrus, Stratus, Sebring, Sebring descapotable, y Avenger)*

1. Corte y retire todas las pestañas de montaje de la carcasa del radio, **EXCEPTO** las pestañas sombreadas.
2. Corte y quite el pin de localización de abajo de la pestaña "A". *En algunas aplicaciones puede ser necesario recortar las pestañas "B".*

*Continuará al ensamble del kit, pág. 1.2*

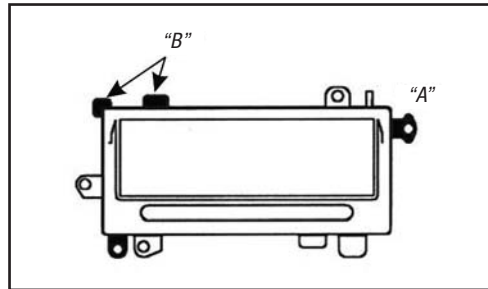

## Chrysler Cirrus 1995- 2000/Sebring (descapotable) 1996-2000, Dodge Stratus 1995-1999/Plymouth Breeze 1996-1999

1. Corte y retire todas las pestañas de montaje de la carcasa del radio, **EXCEPTO** las pestañas sombreadas.
2. Corte y quite el pin de localización de arriba de la pestaña "A".

*Continuará al ensamble del kit, pág. 1.2*

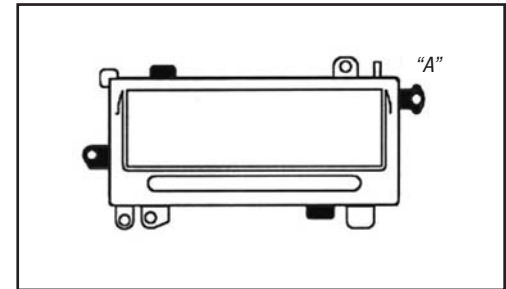

## Chrysler Sebring/Dodge Avenger 1995-2000

1. Corte y retire todas las pestañas de montaje de la carcasa del radio, **EXCEPTO** las pestañas sombreadas.

Continuará al ensamble del kit, pág. 1.2

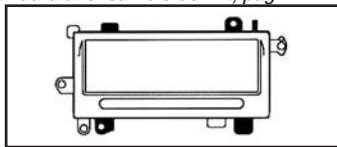

## Jeep Grand Cherokee 1993-1995

1. Corte y retire todas las pestañas de montaje de la carcasa del radio, **EXCEPTO** las pestañas sombreadas.
2. Corte la pestaña "A" a lo largo de la línea marcada y quite la porción de abajo de la pestaña.

Continuará al ensamble del kit, pág. 1.2

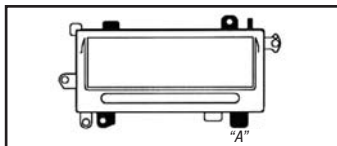

## Provisión de radio DIN

1. Deslice la reja DIN en el kit y sujétela doblando hacia abajo las pestañas de metal.
2. Deslice la unidad central de mercado secundario en la reja hasta que quede firme. (Figura A)
3. Localice el arnés de cableado de fábrica en el tablero. Metra recomienda utilizar el adaptador de acoplamiento correcto de Metra o AXXESS. Reconecte la terminal negativa de la batería y pruebe que la unidad funcione correctamente.
4. Vuelva a armar el tablero al revés de como lo desarmó. (Figura B)

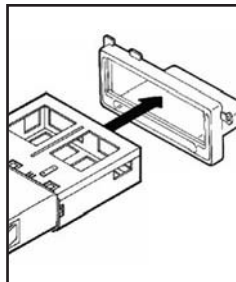

(Figura A)

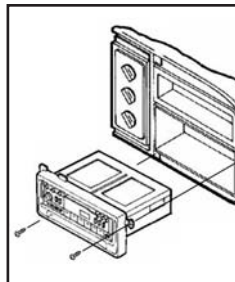

(Figura B)

## Sección 2

### Chrysler/Dodge/Eagle/ Ford/Jeep/Lincoln/Mercury/ Plymouth 1974-2003 99-6500

#### CARACTERÍSTICAS DEL KIT

- Provisión de radio DIN

#### COMPONENTES DEL KIT

- A) Alojamiento del radio

A

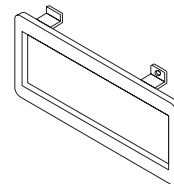

#### HERRAMIENTAS REQUERIDAS

- Destornillador Phillips • Herramienta toma de corriente • Herramienta de corte

## Aplicaciones

<b>Chrysler</b>	<b>Dodge</b> <i>(seguido)</i>	<b>Jeep</b> <i>(seguido)</i>
Concorde 1993-1997	Magnum XE	Wrangler 1997-2000
Cordoba 1975-1983	1978-1979	
E-Class 1983-1993	Mirada 1979-1983	<b>Lincoln</b>
Fifth Avenue	Neon 1994-1999	Continental
1979-1993	Omni 1978-1982	1985-1989
Imperial 1982-1983	Pick-up 1974-1983	Mark VII 1984-1988
Imperial 1990-1994	Ram 1994-2000	
Laser 1984-1989	Ramcharger	<b>Mercury</b>
LeBaron 1977-1995	1974-1993	Colony Park
LeBaron GTS	Rampage 1978-1982	1979-1989
1985-1994	Shadow 1987-1995	Cougar 1983-1988
LHS 1995-1998	Spirit 1989-1995	Cougar XR7
Newport 1977-1980	St. Regis 1979-1981	1980-1982
New Yorker	Van 1978-2003	Grand Marquis
1975-1996		1979-1985
Town & Country	<b>Eagle</b>	Marquis 1979-1988
1990-2000	Vision 1993-1997	
		<b>Plymouth</b>
<b>Dodge</b>	<b>Ford</b>	Acclaim 1989-1995
024 1978-1982	Aerostar 1985-1991	Caravelle 1985-1988
400 1982-1983	Bronco II 1983-1988	Fury 1975-1978
600 1983-1987	Country Squire	Gran Fury 1978-1989
Aries 1981-1989	1979-1989	Horizon 1978-1983
Aspen 1976-1980	Crown Victoria	Neon 1994-1999
Caravan 1984-2000	1983-1989	Reliant 1981-1989
Charger 1974-1978	LTD 1979-1986	Scamp 1983-1984
Charger 1981-1987	Ranger <i>(mini)</i>	Sundance 1987-1994
Dakota 1987-2000	1983-1988	TC3 1978-1982
Daytona 1984-1993	Thunderbird	Trailduster
Diplomat 1976-1989	1980-1988	1975-1981
Durango 1998-2000		Turismo 1983-1987
Dynasty 1988-1993	<b>Jeep</b>	Van 1978-1997
Intrepid 1993-1997	Cherokee 1997-2001	Volare 1976-1980
Lancer 1985-1989	Grand Cherokee	Voyager 1984-2000
	1996-1998	

## Indice 99-6500

### Preparación del kit

- Chrysler 1975-2000** .....	2.1
- Dodge 1974-2003** .....	2.1
- Eagle 1993-1997** .....	2.1
- Ford 1979-1991** .....	2.1
- Jeep 1996-2002** .....	2.1
- Lincoln 1984-1989** .....	2.1
- Mercury 1979-1989** .....	2.1
- Plymouth 1975-2000** .....	2.1

### Ensamble del kit

- Provisión de radio DIN .....	2.2
--------------------------------	-----

**\*\*ATENCIÓN: Consulte en la Sección 6 el desensamble del tablero.**

## Chrysler/Dodge/Eagle/Jeep/ Plymouth 1974-2003

1. Corte y retire todas las pestañas de montaje de la carcasa del radio, **EXCEPTO** las pestañas sombreadas. *En algunas aplicaciones puede ser necesario recortar las pestañas "B".*

*Continuará al ensamble del kit, pág. 2.2*

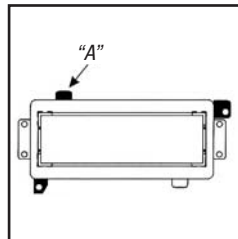

## Ford/Lincoln/Mercury 1974-2003

1. Corte y retire todas las pestañas de montaje de la carcasa del radio, **EXCEPTO** las pestañas sombreadas.

*Continuará al ensamble del kit, pág. 2.2*

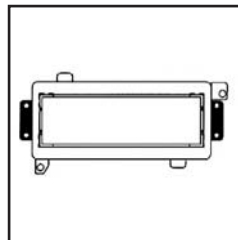

## Provisión de radio DIN

1. Corte y retire los soportes del eje de la carcasa del radio.
2. Deslice la reja DIN en el kit y sujétela doblando hacia abajo las pestañas de metal.
3. Deslice la unidad central de mercado secundario en la reja hasta que quede firme. (Figura A)
4. Ubique el arnés de cableado de fábrica en el tablero. Metra recomienda el uso de un adaptador adecuado de acoplamiento de Metra o de AXXESS. Vuelva a conectar la terminal negativa de la batería y pruebe la unidad para verificar que funcione correctamente.
5. Vuelva a armar el tablero al revés de como lo desarmó. (Figura B)

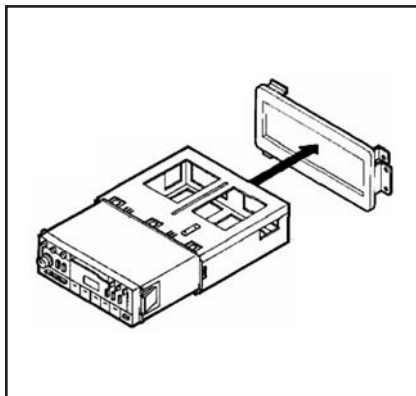

(Figura A)

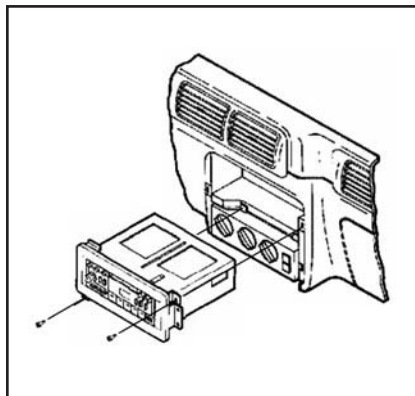

(Figura B)

## Sección 3

### Chrysler/Dodge/Eagle/Ford/ Jeep/Lincoln/Mercury/ Plymouth 1974-2003 99-6501

#### CARACTERÍSTICAS DEL KIT

- DIN e ISO DIN disposiciones

#### COMPONENTES DEL KIT

- A) Alojamiento del radio
- B) Placa frontal ISO DIN
- C) Espaciador
- D) Espaciadores a presión
- E) (2) soportes ISO DIN
- F) (4) tornillos de cabeza plana de 5mm
- G) (2) soportes ISO DIN

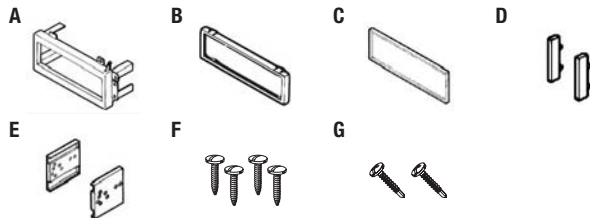

#### HERRAMIENTAS REQUERIDAS

- Destornillador Phillips
- Herramienta toma de corriente
- Herramienta de corte

## Aplicaciones

Chrysler	Dodge (seguido)	Mercury
Concorde 1993-1997	Diplomat 1976-1989	Colony Park 1979-1989
Cordoba 1975-1983	Durango 1998-2000	Cougar 1983-1988
E-Class 1983-1993	Dynasty 1988-1993	Cougar XR7 1980-1982
5th Ave 1979-1993	Intrepid 1993-1997	Grand Marquis 1979-1985
Imperial 1982-1983	Lancer 1985-1989	Marquis 1979-1985
Imperial 1990-1994	Magnum XE 1978-1979	<b>Plymouth</b>
Laser 1984-1989	Mirada 1979-1983	Acclaim 1989-1995
LeBaron 1977-1995	Neon 1994-1999	Caravelle 1985-1987
LeBaron GTS 1985-1994	Omni 1978-1982	Fury 1975-1978
LHS 1995-1998	Pick-up 1974-1983	Gran Fury 1975-1985
Newport 1977-1980	Ram 1994-2000	Horizon 1978-1982
New Yorker 1975-1996	Spirit 1989-1995	Neon 1994-1999
Town & Country 1990-2000	St. Regis 1979-1981	Reliant 1981-1989
	Van 1978-2003	Scamp 1983-1984
	<b>Jeep</b>	Sundance 1987-1994
<b>Dodge</b>	Cherokee 1997-2000	TC3 1978-1982
024 1978-1982	Grand Cherokee 1993-1995	Trailduster 1974-1980
400 1982-1983	Grand Cherokee 1996-1998	Trailduster 1981
600 1983-1987	Wrangler 1997-2000	Turismo 1983-1987
Aries 1981-1989		Van 1978-1997
Aspen 1976-1980	<b>Lincoln</b>	Volare 1976-1980
Caravan 1984-2000	Continental 1984-1988	
Charger 1974-1978	Mark VII 1984-1989	
Charger 1981-1987		
Dakota 1987-2000		
Daytona 1984-1993		

## Indice 99-6501

### Preparación del kit

- Chrysler/Dodge/Eagle/Jeep/Plymouth** .....	3.1
<i>(Except: Grand Cherokee 1993-1995, Sebring y Avenger)</i>	
- Chrysler Sebring 1995-2000** .....	3.2
- Dodge Avenger 1995-2000** .....	3.2
- Ford/Lincoln/Mercury 1979-1989** .....	3.2
- Jeep Grand Cherokee 1993-1995** .....	3.2

### Ensamble del kit

- Provisión de radio ISO DIN.....	3.2-3.3
- Provisión de radio DIN.....	3.3

**\*\*ATENCIÓN: Consulte en la Sección 6 el desensamblado del tablero.**

## Chrysler/Dodge/Eagle/ Jeep/Plymouth

*(Excepto: Grand Cherokee 1993-1995, Sebring y Avenger)*

1. Corte y retire todas las pestañas de montaje de la carcasa del radio, **EXCEPTO** las pestañas sombreadas. *En algunas aplicaciones puede ser necesario recortar las pestañas "A".*

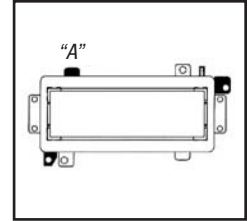

*Continuará al ensamble del kit, pág. 3.2-3*

### Ford/Lincoln/Mercury 1979-1989

1. Corte y retire todas las pestañas de montaje de la carcasa del radio, **EXCEPTO** las pestañas sombreadas.

*Continuará al ensamble del kit,  
pág. 3.2-3*

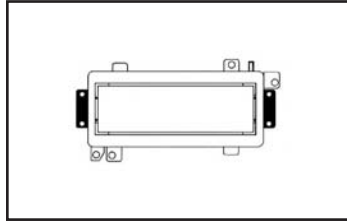

### Chrysler Sebring/Dodge Avenger 1995-2000, Jeep Grand Cherokee 1993-1995

1. Corte y retire todas las pestañas de montaje de la carcasa del radio, **EXCEPTO** las pestañas sombreadas.

*Continuará al ensamble del kit,  
pág. 3.2-3*

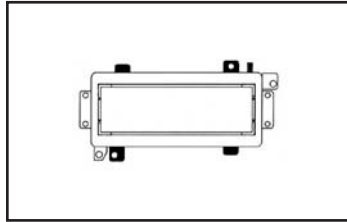

### Provisión de radio ISO DIN

1. Coloque a presión la placa frontal ISO DIN en la carcasa del radio y luego deslice la unidad central de mercado secundario en la parte posterior del kit.
2. Deslice los soportes ISO DIN en las patas de la carcasa y alinee los orificios de los soportes con los orificios de la unidad.
3. Monte los soportes en la unidad con los (4) tornillos de cabeza plana de 5 mm suministrados ("A"). (Figura A)

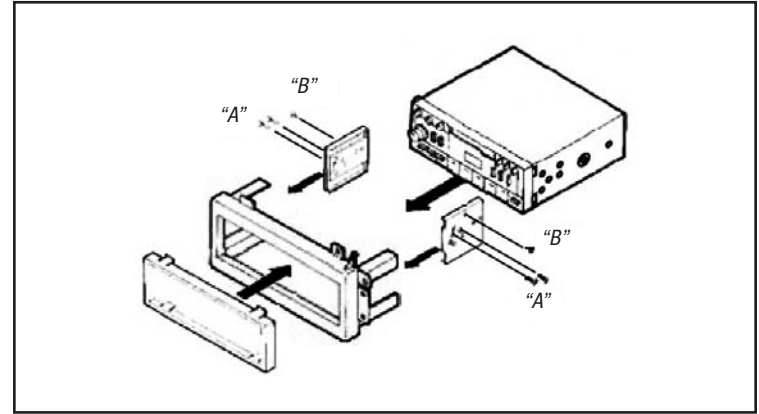

(Figura A)



## Provisión de radio ISO DIN

- Monte los soportes en la parte superior de las patas de la carcasa con (2) tornillos autorroscantes #6 ("B"). (Figura A)
- Ubique el arnés de cableado de fábrica en el tablero. Metra recomienda el uso de un adaptador adecuado de acoplamiento de Metra o de AXCESS. Vuelva a conectar la terminal negativa de la batería y pruebe la unidad para verificar que funcione correctamente.
- Vuelva a armar el tablero al revés de como lo desarmó.

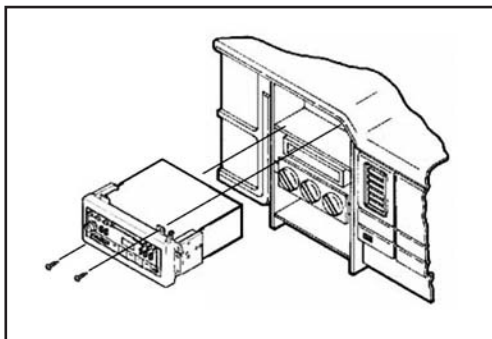

(Figura B)

## Provisión de radio DIN

- Si se desea una instalación de montaje superficial,** inserte el espaciador en la carcasa del radio. (Figura A)
- Deslice la reja DIN en el kit y sujétela doblando hacia abajo las pestañas de metal. Deslice la unidad central de mercado secundario en la reja hasta que quede firme.
- Si se desea una instalación de montaje intermedio,** coloque los espaciadores a presión en las paredes exteriores de la apertura del radio. (Figura B)
- Deslice la reja DIN en la carcasa del radio y sujétela doblando hacia abajo las pestañas de metal. Deslice la unidad central de mercado secundario en la reja hasta que quede firme.
- Si se desea una instalación de montaje al ras,** deslice la reja DIN en la carcasa del radio y sujétela doblando hacia abajo las pestañas de metal. (Figura C)
- Deslice la unidad central de mercado secundario en la reja hasta que quede firme.
- Locate the factory wiring harness in the dash. Metra recommends using the proper mating adapter from Metra or AXCESS. Re-connect the negative battery terminal and test the unit for proper operation.
- Vuelva a armar el tablero al revés de como lo desarmó.

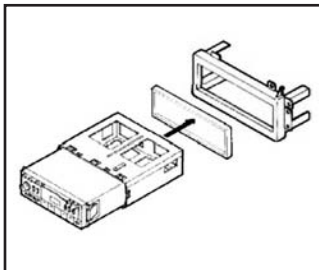

(Figura A)

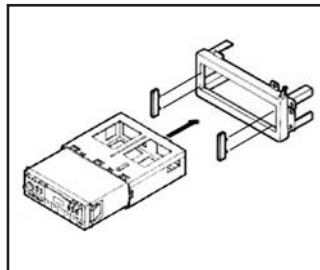

(Figura B)

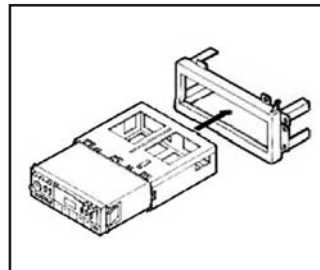

(Figura C)

## Sección 4

# Chrysler/Eagle/Ford/ Jeep 1974-2003 99-6700

### CARACTERÍSTICAS DEL KIT

- Recessed DIN for flush mount provision

### COMPONENTES DEL KIT

- A) Alojamiento del radio • B) Separadores de soporte  
(Avenger/Sebring)

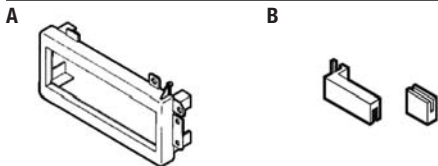

### HERRAMIENTAS REQUERIDAS

- Destornillador Phillips • Herramienta de corte
- Herramienta toma de corriente

## Aplicaciones

<b>Chrysler</b>	Avenger	1995-2000	400	1982-1983	
Cirrus	1995-2000	Caravan	1984-1990	600	1983-1987
Concorde	1993-1997	Caravan	1991-1995		
Cordoba	1975-1978	Caravan	1996-2000	<b>Eagle</b>	
Cordoba	1979-1983	Charger	1974-1978	Vision	1993-1997
E-Class	1984-1993	Charger	1981-1983		
Fifth Avenue		Dakota	1987-1996	<b>Ford</b>	
	1979-1993	Dakota	1997-2000	Aerostar	1985-1991
Imperial	1982-1983	Daytona	1984-1989	Bronco II	1985-1988
Imperial	1990-1994	Daytona	1990-1993	Crown Victoria	
Laser	1984-1989	Diplomat	1976-1989		1979-1990
LeBaron	1976-1981	Durango	1997-2000	LTD	1979-199
LeBaron	1984-1985	Dynasty	1988-1993	Ranger (mini)	
LeBaron	1986-1995	Intrepid	1993-1997		1985-1988
LeBaron GTS		Lancer	1985-1989	Thunderbird	
	1985-1994	Magnum XE			1985-1988
LHS	1995-1998		1978-1979	<b>Jeep</b>	
Newport	1977-1981	Mirada	1979-1982	Cherokee	1997-2001
New Yorker		Neon	1994-1999	Grand Cherokee	
	1980-1981	Omni	1978-1990		1993-1995
New Yorker		Pickup	1974-1980	Grand Cherokee	
	1983-1987	Pickup	1981-1993		1996-1998
New Yorker		Ram	1994-2001	Wrangler	1997-2002
	1994-1996	Ram 2500/3500			
Prowler	1997-2002		2002	<b>Lincoln</b>	
Sebring	1995-2000	Ramcharger		Continental	
Sebring (conv)			1974-1980		1985-1987
	1996-2000	Ramcharger		Mark VII	1984-1989
Town & Country			1981-1993	<b>Mercury</b>	
	1990-1995	Rampage	1978-1982	Cougar	1985-1988
Town & Country		Shadow	1987-1994	Grand Marquis	
	1996-2000	Spirit	1989-1995		1979-1990
<b>Dodge</b>		St Regis	1979-1981	Marquis	1979-1990
Aries	1981-1989	Stratus	1995-2000		
Aspen	1976-1980	Van	1978-2003		
		024	1978-1982		

## Aplicaciones

<b>Plymouth</b>	Reliant	1981-1989	Van	1978-1997	
Acclaim	1989-1995	Scamp	1983-1984	Volare	1976-1980
Breeze	1996-1999	Sundance	1987-1994	Voyager	1984-1990
Caravelle	1985-1987	TC3	1978-19821	Voyager	1991-1995
Fury	1975-1978	Trailduster		Voyager	1996-2000
Gran Fury	1975-1985		1974-1980		
Horizon	1978-1982	Trailduster	1981		
Neon	1994-1999	Turismo	1983-1987		

## Indice 99-6700

### Desmontaje del tablero

- Chrysler/Dodge/Eagle/Jeep/Plymouth (Except: Grand Cherokee 1993-1995, Cirrus, Stratus, Sebring, Sebring descapotable, y Avenger)..... 4.1
- Chrysler Cirrus 1995-2000/Sebring (descapotable) 1996-2000, Dodge Stratus 1995-2000, Plymouth Breeze 1996-1999..... 4.1
- Chrysler Sebring/Dodge Avenger 1995-2000 ..... 4.1
- Ford/Lincoln/Mercury ..... 4.1
- Jeep Grand Cherokee 1993-1995 ..... 4.1

### Ensamble del kit

- Provisión de radio DIN..... 4.2

**Chrysler/Dodge/Eagle/  
Jeep/Plymouth**

*(Except: Grand Cherokee 1993-1995, Cirrus, Stratus, Sebring, Sebring descapotable, y Avenger)*

1. Corte y retire todas las pestañas de montaje de la carcasa del radio, **EXCEPTO** las pestañas sombreadas.

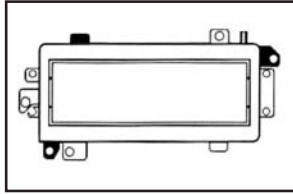

*Continuará al ensamble del kit, pág. 4.2*

**Ford/Lincoln/  
Mercury**

1. Corte y retire todas las pestañas de montaje de la carcasa del radio, **EXCEPTO** las pestañas sombreadas.

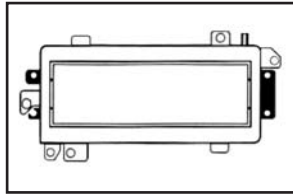

*Continuará al ensamble del kit, pág. 4.2*

**Chrysler Cirrus 1995-2000/  
Sebring (descapotable) 1996-2000,  
Dodge Stratus 1995-2000,  
Plymouth Breeze 1996-1999**

1. Corte y retire todas las pestañas de montaje de la carcasa del radio, **EXCEPTO** las pestañas sombreadas.

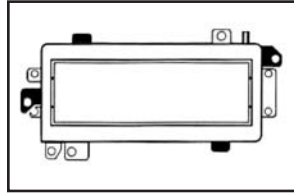

*Continuará al ensamble del kit, pág. 4.2*

**Jeep Grand Cherokee  
1993-1995**

1. Corte y retire todas las pestañas de montaje de la carcasa del radio, **EXCEPTO** las pestañas sombreadas.

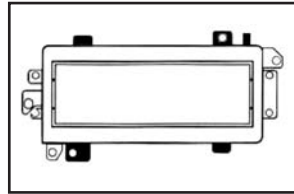

*Continuará al ensamble del kit, pág. 4.2*

**Chrysler Sebring/Dodge  
Avenger 1995-2000**

1. Corte y retire todas las pestañas de montaje de la carcasa del radio, **EXCEPTO** las pestañas sombreadas. (Figura A)

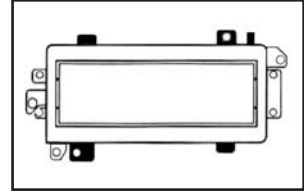

(Figura A)

2. Luego coloque separadores de apoyo incluidas, como se muestra. (Figura B)

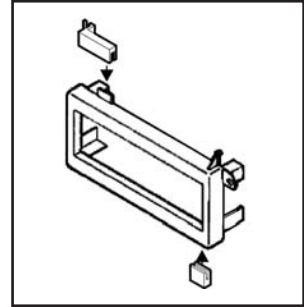

(Figura B)

*Continuará al ensamble del kit, pág. 4.2*

## Provisión de radio DIN

1. Deslice la reja DIN en el kit y sujétela doblando hacia abajo las pestañas de metal.
2. Deslice la unidad central de mercado secundario en la reja hasta que quede firme. (Figura A)
3. Ubique el arnés del cableado de fábrica en el tablero. Metra recomienda usar el adaptador de acoplamiento adecuado de Metra o AXCESS. Vuelva a conectar el terminal negativo de la batería y pruebe la unidad para verificar que funcione correctamente.
4. Vuelva a montar el tablero en forma inversa al desmontaje. (Figura B)

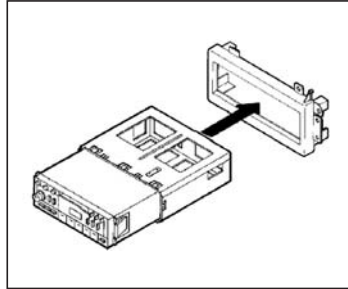

(Figura A)

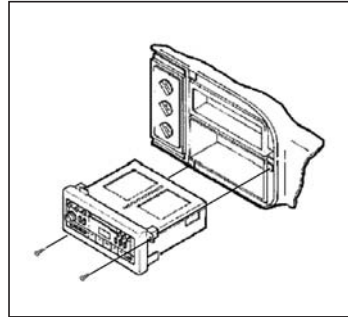

(Figura B)

## Notas

---

---

---

---

---

---

---

---

---

---

---

---

---

---

---

---

---

---

---

---

---

---

---

---

## Sección 5

# Dodge/Eagle/Mitsubishi/ Plymouth 1985-1996 99-7000

### CARACTERÍSTICAS DEL KIT

- Provisión con bolsillo

### COMPONENTES DEL KIT

- A) Radio housing • B) Carcasa del ecualizador
- C) Placa frontal • D) Juego de soportes #1
- E) Juego de soportes #2 • F) Barra de relleno
- G) Placa frontal simuladora de ecualizador • H) (6) tornillos de cabeza hexagonal #8 x 3/4" • I) (4) tornillos de cabeza hexagonal #8 x 1/2"

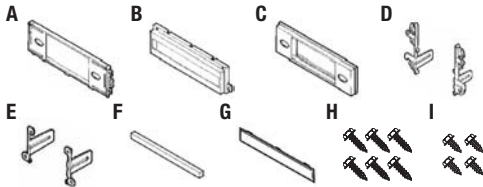

### HERRAMIENTAS REQUERIDAS

- Destornillador Phillips • Herramienta de corte

## Aplicaciones

<b>Dodge</b>		<b>Eagle</b> ( <i>seguido</i> )		Mirage	1989-1992
Colt	1987-1988	Talon	1990-1994	Montero	1987-1991
Colt	1989-1992			Sigma	1989-1990
D-50 pick-up	1987-1993	<b>Mitsubishi</b>		Van	1987-1990
Raider	1987-1991	Eclipse	1990-1994	<b>Plymouth</b>	
		Expo	1992-1995	Colt Vista	1992-1994
		Galant	1985-1988	Laser	1990-1994
<b>Eagle</b>		Galant	1989-1993		
Summit	1989-1992	Mighty Max pick-up			
Summit ( <i>wagoneta</i> )	1987-1996				
	1992-1996	Mirage	1985-1988		

## Indice 99-7000

### Desmontaje del tablero

- Dodge Colt 1987-1988.....	5.0-5.1
- Dodge Colt 1989-1992.....	5.1
- Dodge D-50 pick-up 1987-1993.....	5.2
- Dodge Raider 1987-1991.....	5.2-5.3
- Eagle Summit 1989-1992.....	5.1
- Eagle Summit ( <i>wagoneta</i> ) 1992-1996.....	5.3
- Eagle Talon 1990-1994.....	5.4
- Mitsubishi Eclipse 1990-1994.....	5.4
- Mitsubishi Expo 1992-1995.....	5.3
- Mitsubishi Galant 1985-1988.....	5.4
- Mitsubishi Galant 1989-1993.....	5.5

## Indice

- Mitsubishi Mighty Max pick-up 1987-1996.....	5.2
- Mitsubishi Mirage/Dodge Colt 1985-1988.....	5.0-5.1
- Mitsubishi Mirage/Dodges Colt 1989-1992.....	5.1
- Mitsubishi Montero 1987-1991.....	5.2-5.3
- Mitsubishi Sigma 1989-1990.....	5.4
- Mitsubishi Van 1987-1990.....	5.5
- Plymouth Colt Vista 1992-1994.....	5.3
- Plymouth Laser 1990-1994.....	5.4

### Ensamble del kit

- Provisión de radio 2-eje.....	5.6
- Provisión de radio DIN.....	5.6

## Dodge Colt 1987-1988, Mitsubishi Mirage 1985-1988

1. Quite el cenicero y los (2) tornillos expuestos.
2. Desenganche el bisel de la moldura de la palanca de velocidades y quite los (4) tornillos expuestos.
3. Saque a presión el interruptor de las luces intermitentes y quite el tornillo expuesto (1).
4. Quite la tapa simuladora localizada debajo de la  
*Continúa en la página*

### Dodge Colt 1987-1988, Mitsubishi Mirage 1985-1988

palanca de freno y los (2) tornillos expuestos.

5. Quite los tornillos que sujetan la unidad central de fábrica y desconecte el cableado. (Figura A)
6. Coloque a presión la barra de relleno en la carcasa del ecualizador y deslice el ensamble en la parte inferior de la carcasa del radio. (Figura B)
7. Monte el juego de soportes #2 en la parte posterior de la carcasa del ecualizador con los (4) tornillos de cabeza hexagonal #8 x 1/2" suministrados. (Figura C)

Continuará al  
ensamble del kit,  
pág. 5.6

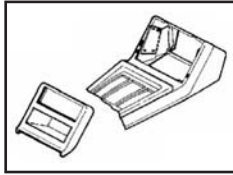

(Figura A)

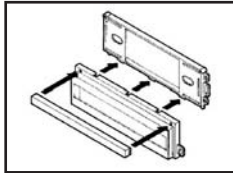

(Figura B)

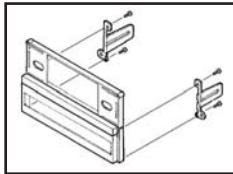

(Figura C)

### Dodge Colt/Eagle Summit/Mitsubishi Mirage 1989-1992

1. Quite los (2) tornillos Phillips de arriba de los controles del clima.
2. Quite los (2) tornillos Phillips del borde inferior del bisel de la moldura del radio y quite el bisel.
3. Quite los (4) tornillos Phillips que sujetan la unidad central de fábrica y desconecte el cableado. (Figura A)

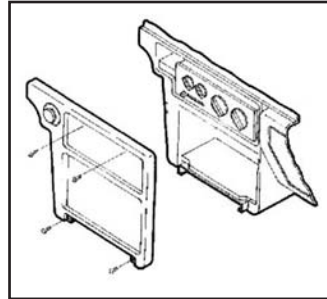

(Figura A)

4. Coloque a presión la barra de relleno en la carcasa del ecualizador y deslice el ensamble en la parte inferior de la carcasa del radio. (Figura B)

**Nota:** La cavidad de fábrica puede usarse omitiendo este paso y montando la cavidad debajo de la carcasa del radio durante la instalación.

5. Corte y quite todas las pestañas de montaje del Juego de

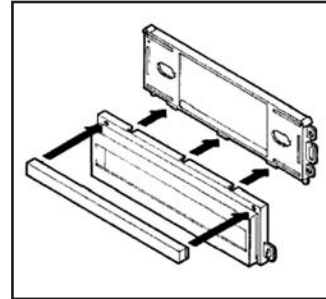

(Figura B)

soportes #1, **EXCEPTO** las pestañas "B". (Figura C)

6. Monte los soportes convertidos en la parte posterior del ensamble con los (6) tornillos de cabeza hexagonal #8 x 3/4" suministrados.

Continuará al ensamble del kit,  
pág. 5.6

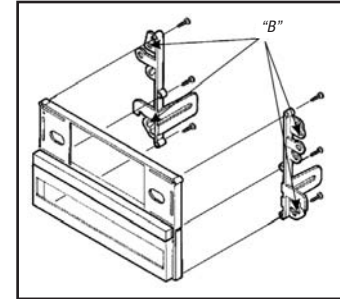

(Figura C)

Mounting tab(s): identified by a stamped letter on back of tab

### Dodge D-50 pick-up 1987-1993 Mitsubishi Mighty Max 1987-1996

1. Quite los (2) tornillos localizados debajo de las rejillas del aire acondicionado. Quite las perillas del control de clima.
2. Quite los (2) tornillos de arriba de los controles de clima.
3. Usando un destornillador pequeño, desenganche la parte superior del bisel de la moldura del radio y quite el bisel.
4. Quite los (4) tornillos Phillips que sujetan la unidad central

de fábrica y desconecte el cableado. (Figura A)

5. Coloque a presión la barra de relleno en la carcasa del ecualizador y deslice el ensamblaje en la parte inferior de la carcasa del radio. (Figura B)

**Nota:** La cavidad de fábrica puede usarse omitiendo este paso y montando la cavidad debajo de la carcasa del radio durante la instalación.

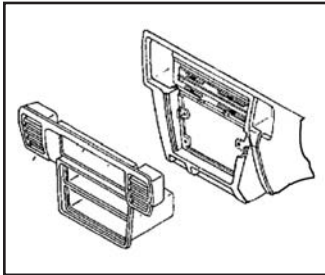

(Figura A)

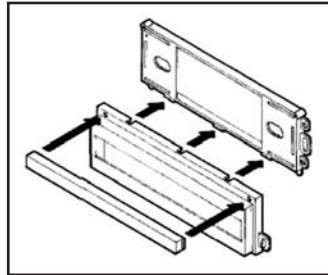

(Figura B)

6. Corte y quite todas las pestañas de montaje del Juego de soportes #1, **EXCEPTO** las pestañas "F". (Figura C)
7. Monte los soportes convertidos en la parte posterior del ensamblaje con los (6) tornillos de cabeza hexagonal #8 x 3/4" suministrados.

*Continuará al ensamble del kit, pág. 5.6*

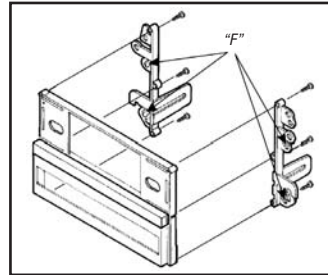

(Figura C) Pestaña(s) de montaje: identificadas por una letra estampada en la parte posterior de la pestaña

### Dodge Raider/Mitsubishi Montero 1987-1991

1. Quite las perillas de control de clima y luego quite los (2) tornillos de arriba de los controles de clima.
2. Quite las tapas de la cubierta de los lados de la consola del tablero y quite los (4) tornillos expuestos.
3. Quite los (4) tornillos de la placa de la palanca de velocidades y quite la placa.
4. Jale el ensamblaje de la consola del tablero hacia adelante y desconecte el cableado.
5. Quite los (4) tornillos que sujetan el bisel de la moldura del radio a la consola y quítelo.
6. Quite los (4) tornillos que sujetan la unidad central de fábrica y desconecte el cableado. (Figura A)

*Continúa en la página*

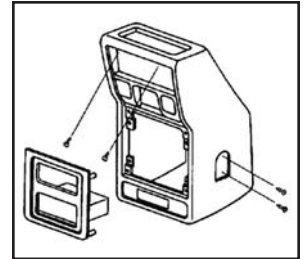

(Figura A)

### Dodge Raider/Mitsubishi Montero 1987-1991

- Coloque a presión la barra de relleno en la carcasa del equalizador y deslice el ensamble en la parte inferior de la carcasa del radio. (Figura B)

**Nota:** La cavidad de fábrica puede usarse omitiendo este paso y montando la cavidad debajo de la carcasa del radio durante la instalación.

- Corte y quite todas las pestañas de montaje del Juego de soportes #1, **EXCEPTO** las pestañas "B". (Figura C)
- Monte los soportes convertidos en la parte posterior del ensamble con los (6) tornillos de cabeza hexagonal #8 x 3/4" suministrados.

Continuará al ensamble del kit, pág. 5.6

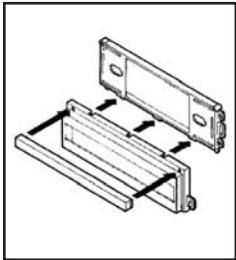

(Figura B)

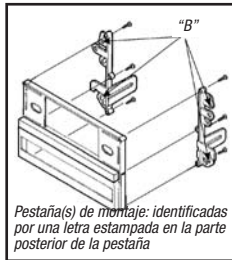

Pestaña(s) de montaje: identificadas por una letra estampada en la parte posterior de la pestaña

(Figura C)

### Eagle Summit (vagoneta) 1992-1996, Mitsubishi Expo 1992-1995, Plymouth Colt Vista 1992-1994

- Quite los (2) tornillos de la parte superior del bisel de la moldura del radio.
- Quite el cenicero y los (2) tornillos expuestos.
- Desenganche el bisel de la moldura del radio y desconecte el cableado del encendedor.
- Quite los tornillos que sujetan la unidad central de fábrica y desconecte el cableado. (Figura A)
- Coloque a presión la barra de relleno en la carcasa del equalizador y deslice el ensamble en la parte inferior de

la carcasa del radio. (Figura B)

- Corte y quite todas las pestañas de montaje de la carcasa del radio, **EXCEPTO** las pestañas "D". (Figura C)

Continuará al ensamble del kit, pág. 5.6

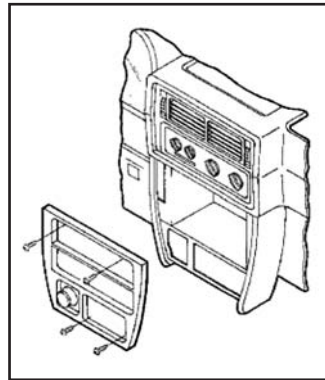

(Figura A)

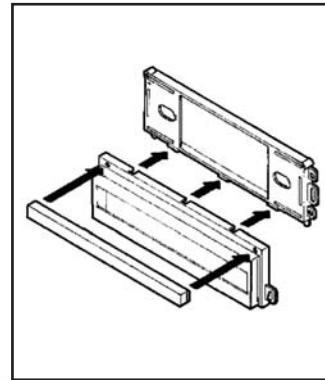

(Figura B)

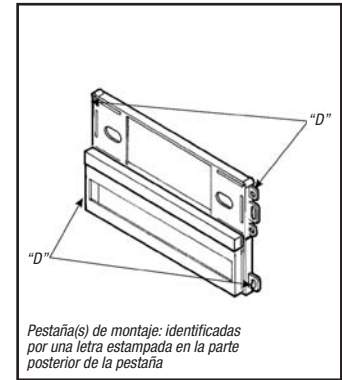

Pestaña(s) de montaje: identificadas por una letra estampada en la parte posterior de la pestaña

(Figura C)



### Eagle Talon/Mitsubishi Eclipse/Plymouth Laser 1990-1994

1. Desenganche el bisel de la moldura del radio y quite.
2. Quite los (4) tornillos Phillips que sujetan la unidad central de fábrica y desconecte el cableado. (Figura A)
3. Coloque a presión la barra de relleno en la carcasa del ecualizador y deslice el ensamblaje en la parte inferior de la carcasa del radio. (Figura B)
4. Corte y quite todas las pestañas de montaje de la carcasa del radio, **EXCEPTO** las pestañas "D". (Figura C)

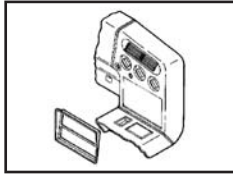

(Figura A)

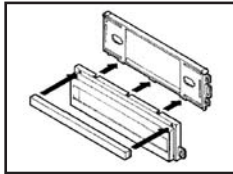

(Figura B)

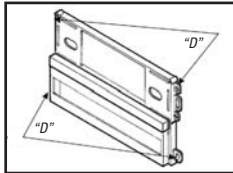

(Figura C)

Continuará al ensamble del kit, pág. 5.6

### Mitsubishi Galant 1985-1988 Mitsubishi Sigma 1989-1990

1. Desenganche el bisel de la moldura del radio y quite.
2. Quite los (4) tornillos que sujetan la unidad central de fábrica y desconecte el cableado. (Figura A)
3. Coloque a presión la barra de relleno en la carcasa del ecualizador y deslice el ensamblaje en la parte inferior de la carcasa del radio. (Figura B)

**Nota:** La cavidad de fábrica puede usarse omitiendo este paso y montando la cavidad debajo

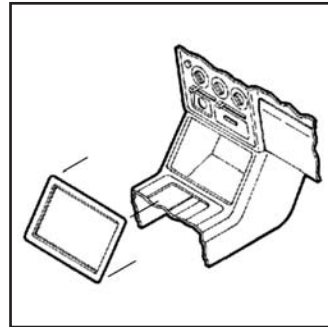

(Figura A)

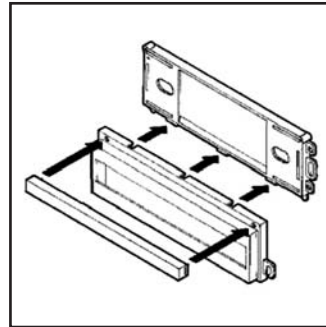

(Figura B)

de la carcasa del radio durante la instalación.

4. Corte y quite todas las pestañas de montaje del Juego de soportes #1, EXCEPTO las pestañas "H".
5. Monte los soportes convertidos en la parte posterior del ensamblaje con los (6) tornillos de cabeza hexagonal #8 x 3/4" suministrados. (Figura C)

Continuará al ensamble del kit, pág. 5.6

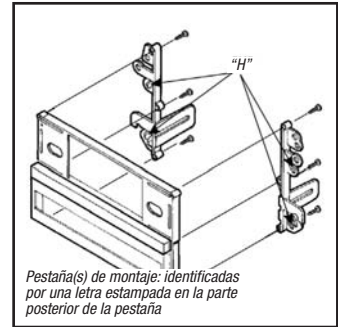

Pestaña(s) de montaje: identificadas por una letra estampada en la parte posterior de la pestaña

(Figura C)

### Mitsubishi Galant 1989-1993

1. Desenganche el bisel de la moldura del radio y quite.
2. Quite los (4) tornillos que sujetan la unidad central de fábrica y desconecte el cableado. (Figura A)
3. Coloque a presión la barra de relleno en la carcasa del ecualizador y deslice el ensamble en la parte inferior de la carcasa del radio. (Figura B)
4. Corte y quite todas las pestañas de montaje de la carcasa del radio, **EXCEPTO** las pestañas "G". (Figura C)

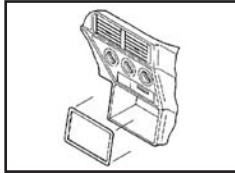

(Figura A)

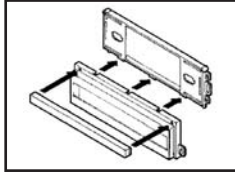

(Figura B)

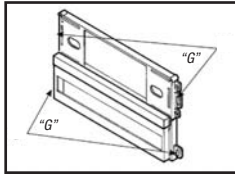

(Figura C) Pestaña(s) de montaje: identificadas por una letra estampada en la parte posterior de la pestaña

Continuará al  
ensamble del kit,  
pág. 5.6

### Mitsubishi Van 1987-1990

1. Quite los (3) tornillos del borde inferior del bisel de la moldura del tablero y quite el bisel.
2. Quite los (4) tornillos que sujetan la unidad central de fábrica y desconecte el cableado. (Figura A)
3. Coloque a presión la barra de relleno en la carcasa del ecualizador y deslice el ensamble en la parte inferior de la carcasa del radio. (Figura B)

**Nota:** La cavidad de fábrica puede usarse

*omitiendo este paso y montando la cavidad debajo de la carcasa del radio durante la instalación.*

4. Corte y quite todas las pestañas de montaje del Juego de soportes #1, EXCEPTO las pestañas "H".
5. Monte los soportes convertidos en la parte posterior del ensamble con los (6) tornillos de cabeza hexagonal #8 x 3/4" suministrados.

*Continuará al ensamble del kit, pág. 5.6*

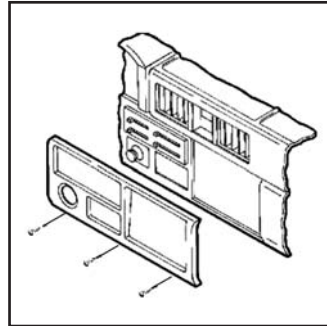

(Figura A)

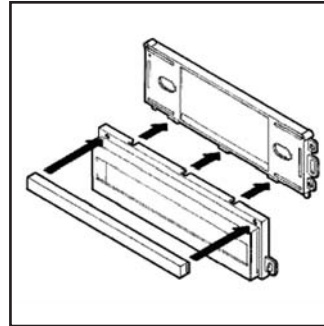

(Figura B)

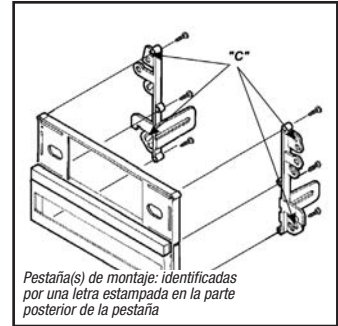

Pestaña(s) de montaje: identificadas por una letra estampada en la parte posterior de la pestaña

(Figura C)

## Provisión de radio 2-eje

1. Coloque la placa frontal en la carcasa del radio.
2. Deslice la unidad central de mercado secundario en el kit y sujétela con las tuercas de eje. (Figura A)
3. Ubique el arnés de cableado de fábrica en el tablero. Metra recomienda el uso de un adaptador adecuado de acoplamiento de Metra o de AXXESS. Vuelva a conectar la terminal negativa de la batería y pruebe la unidad para verificar que funcione correctamente.
4. Vuelva a armar el tablero al revés de como lo desarmó.

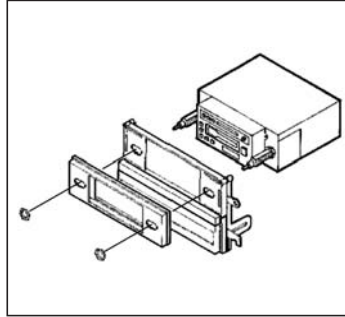

(Figura A)

## Provisión de radio DIN

1. Corte y quite los soportes del eje.
2. Deslice la reja DIN en la carcasa del radio y sujétela doblando hacia abajo las pestañas de metal.
3. Deslice la unidad central de mercado secundario en la reja hasta que quede firme. (Figura A)

**Nota:** Si se incluirá un ecualizador, deslice la unidad en la parte posterior de la carcasa del radio y sujete. Si NO se incluirá un ecualizador, coloque a presión la placa simuladora del ecualizador en la apertura.

4. Ubique el arnés de cableado de fábrica en el tablero. Metra recomienda el uso de un adaptador adecuado de acoplamiento de Metra o de AXXESS. Vuelva a conectar la terminal negativa de la batería y pruebe la unidad para verificar que funcione correctamente.
5. Vuelva a armar el tablero al revés de como lo desarmó. (Figura B)

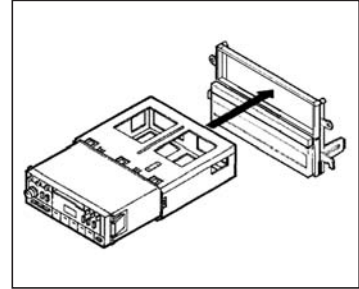

(Figura A)

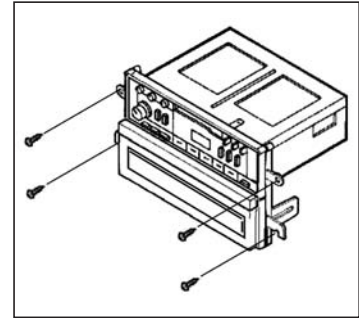

(Figura B)

## Sección 6

### 99-6000, 99-6500, 99-6501

Chrysler/Dodge/Eagle/Ford/Jeep/Lincoln  
Mercury/Plymouth

## Varios Desensambles del tablero

*INST-6000 es una colección de instructivos de instalación. Utilice la Información general sobre aplicación al seleccionar cuáles instrucciones de instalación utilizar. Cada sección está configurada como un capítulo con su propio índice.*

### Desmontaje del tablero

- Chrysler Cirrus/Dodge Stratus 1995-2000, Plymouth Breeze 1996-1999 .....	6.1
- Chrysler Concorde/LHS 1995-1998, Dodge Intrepid/Eagle Vision 1993-1997 .....	6.1
- Chrysler Cordoba/Plymouth Fury 1975-1978, Dodge Charger 1974-1978, Magnum XE 1978-1979.....	6.1
- Chrysler Cordoba 1979-1983/Imperial 1982-1983/Newport 1980-1981, Dodge Mirada 1980-1983/ St. Regis 1979-1981 .....	6.1
- Chrysler E-Class 1983-1984/LeBaron 1982-1985/New Yorker 1983-1987, Dodge Aries 1981-1989/400 1982-1983/600 1983-1987, Plymouth Caravelle 1985-1987/Reliant 1981-1989 .....	6.2
- Chrysler 5th Avenue/Imperial 1990-1994/ New Yorker 1988-1995, Dodge Dynasty 1988-1993.....	6.2
- Chrysler Laser/Dodge Daytona 1984-1989.....	6.2
- Chrysler Laser/Dodge Daytona 1984-1989.....	6.2
- Chrysler LeBaron 1984-1995 .....	6.2
- Chrysler LeBaron GTS 1985-1994, Dodge Lancer 1985-1989 .....	6.3

## Índice

- Chrysler LeBaron 1976-1981, Dodge Diplomat 1976-1989/Aspen 1976-1980, Plymouth Gran Fury 1975-1985/ Volare 1976-1980.....	6.3
- Chrysler Sebring/Dodge Avenger 1995-2000.....	6.3
- Chrysler Sebring (descapotable) 1995-2000 .....	6.3
- Chrysler Town & Country 1990-1995, Dodge Caravan/Plymouth Voyager 1984-1990 .....	6.4
- Dodge Caravan/Plymouth Voyager 1991-1995.....	6.4
- Dodge Caravan/Chrysler Town & Country/ Plymouth Voyager 1996-2000.....	6.4
- Dodge Caravan/Chrysler Town & Country/ Plymouth Voyager 1996-2000.....	6.4
- Dodge Charger/Plymouth Turismo 1983-1987 .....	6.4
- Dodge Dakota 1987-1996 .....	6.5
- Dodge Dakota 1997-2000 .....	6.5
- Dodge Daytona 1990-1993 .....	6.5
- Dodge Durango 1997-2000.....	6.5
- Dodge Neon/Plymouth Neon 1994-1999 ..	6.5
- Dodge Omni/024/Rampage 1978-1982, Plymouth Horizon/TC3 1978-1982/ Scamp 1983-1984.....	6.6
- Dodge Pickup/Ramcharger 1974-1980, Plymouth Trailduster 1974-1980 .....	6.6
- Dodge Pickup/Ramcharger 1974-1980, Plymouth Trailduster 1974-1980 .....	6.6
- Dodge Pickup/Ramcharger 1981-1993, Plymouth Trailduster 1981 .....	6.6
- Dodge Ram 1994-2001, Ram 2500/3500 2002.....	6.6
- Dodge Shadow/Plymouth Sundance 1987-1994 .....	6.7
- Dodge Spirit/Plymouth Acclaim 1989-1995 .....	6.7
- Dodge Van/Plymouth Van 1978-2003 .....	6.7
- Ford Aerostar 1985-1991 .....	6.7
- Ford Bronco II/ Ranger (mini) 1985-1988.....	6.7
- Ford Crown Victoria/LTD 1979-1990, Mercury Grand Marquis/ Marquis 1979-1990 .....	6.7
- Ford Thunderbird/Mercury Cougar 1985-1988 .....	6.8
- Jeep Cherokee 1997-2001.....	6.8
- Jeep Grand Cherokee 1993-1995 .....	6.8
- Jeep Grand Cherokee 1996-1998 .....	6.8
- Jeep Wrangler 1997-2002 .....	6.8
- Lincoln Continental 1985-1987 .....	6.9
- Lincoln Mark VII 1984-1989 .....	6.9

**Chrysler Cirrus/Dodge Stratus 1995-2000, Plymouth Breeze 1996-1999**

1. Usando un destornillador de paleta, haga palanca hacia afuera en los bordes del bisel de la moldura del radio.
2. Desenganche el bisel y quite.
3. Quite los (2) tornillos de cabeza hexagonal de 3/8" que sujetan la unidad central de fábrica y desconecte el cableado.

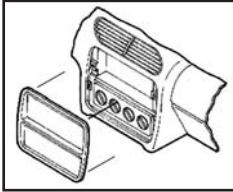
**Chrysler Cordoba/ Plymouth Fury 1975-1978, Dodge Charger 1974-1978, Magnum XE 1978-1979**

1. Quite los (4) tornillos Phillips del borde inferior del bisel de la moldura del radio.
2. Quite los (2) tornillos Phillips de arriba de la apertura del radio.
3. Desatornille el anillo retenedor que sujeta el control remoto del espejo y retire el bisel.
4. Quite los (2) tornillos de cabeza hexagonal de 3/8" que sujetan la unidad central de fábrica y desconecte el cableado.

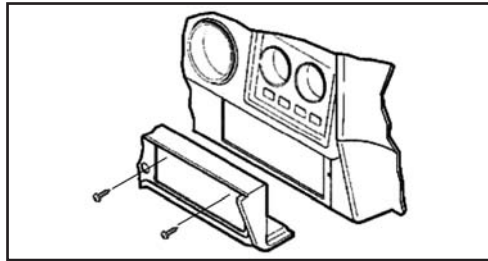
**Chrysler Cordoba 1979-1983/Imperial 1982-1983/ Newport 1980-1981/New Yorker 1980-1981, Dodge Mirada 1980-1983/St. Regis 1979-1981**

1. Quite los (2) tornillos Phillips de arriba de la apertura del radio.
2. Quite los (2) tornillos Phillips de arriba de los controles del clima.
3. Desenganche el bisel de la moldura del tablero y quite.
4. Quite los (2) tornillos de cabeza hexagonal de 3/8" que sujetan la unidad central de fábrica y desconecte el cableado.

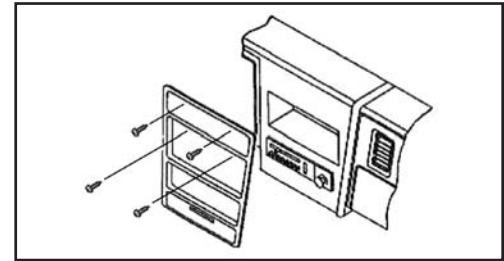
**Chrysler Concorde/LHS 1995-1998, Dodge Intrepid/ Eagle Vision 1993-1997**

1. Desenganche el bisel de la moldura del radio y quite.
2. Quite los (2) tornillos de cabeza hexagonal de 3/8" que sujetan la unidad central de fábrica y desconecte el cableado.

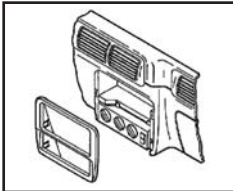

### **Chrysler E-Class 1983-1984/ LeBaron 1982-1985/New Yorker 1983-1987 Dodge Aries 1981-1989/400 1982-1983/600 1983-1987 Plymouth Caravelle 1985- 1987/Reliant 1981-1989**

1. Quite los (3) tornillos Phillips del borde superior del bisel de la moldura del tablero.
2. Quite los (3) tornillos Phillips del borde inferior del bisel de la moldura del radio.
3. Desenganche el bisel y desconecte el cableado.
4. Quite los (2) pernos de cabeza hexagonal de 3/8" que sujetan la unidad central de fábrica y desconecte el cableado.

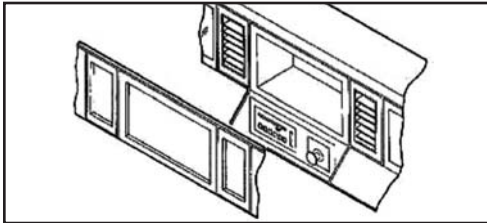

### **Chrysler 5th Avenue/ Imperial 1990-1994/New Yorker 1988-1995, Dodge Dynasty 1988-1993**

1. Quite los (2) tornillos Phillips de arriba de la apertura del radio.
2. Quite los (2) tornillos Phillips de arriba de los controles del clima.
3. Desenganche el bisel
4. Quite los (2) tornillos de cabeza hexagonal de 3/8" que sujetan la unidad central de fábrica y desconecte el cableado.

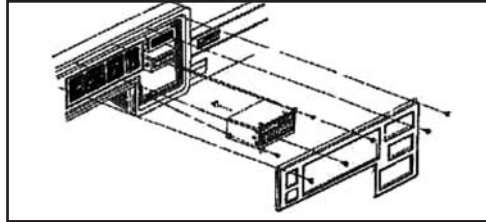

### **Chrysler Laser/Dodge Daytona 1984-1989**

1. Quite los (2) tornillos Phillips de la base del bisel de la moldura del tablero.

### **Chrysler Laser/Dodge Daytona 1984-1989**

2. Jale hacia afuera el borde inferior del bisel y retírelo.
3. Quite los (2) tornillos de cabeza hexagonal de 3/8" que sujetan la unidad central de fábrica y desconecte el cableado.

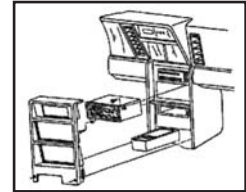

### **Chrysler LeBaron 1984-1995**

1. Quite (1) tornillo Phillips de la esquina inferior del bisel de la moldura del tablero.
2. Desenganche el bisel y quite.
3. Quite los (2) tornillos Phillips del panel derecho de la consola y retire el panel.
4. Quite los (2) tornillos de cabeza hexagonal que sujetan la unidad central de fábrica y desconecte el cableado.

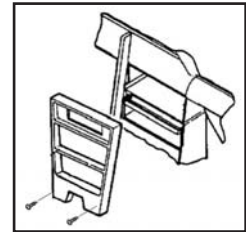

### **Chrysler LeBaron GTS 1985-1994, Dodge Lancer 1985-1989**

1. Quite los (5) tornillos de cabeza Torx de la parte superior del bisel de la moldura del tablero.
2. Quite los (2) tornillos de cabeza Torx de abajo de la apertura del radio.
3. Quite (1) tornillo de cabeza Torx de la esquina superior izquierda de la apertura del radio.
4. Quite los (4) tornillos de cabeza Torx del área inferior del bisel de la moldura del tablero.
5. Desenganche el bisel y quite.
6. Quite los (2) pernos de cabeza hexagonal de 3/8" que sujetan la unidad central de fábrica y desconecte el cableado.

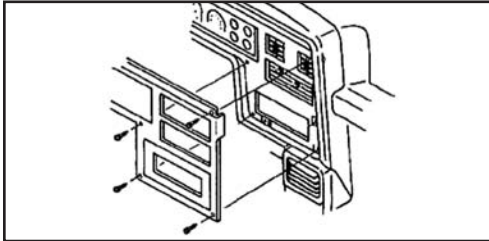

### **Chrysler LeBaron 1976- 1981, Dodge Diplomat 1976-1989/Aspen 1976-1980, Plymouth Gran Fury 1975-1985/Volare 1976-1980**

1. Quite los (4) tornillos Phillips de la parte superior del bisel de la moldura del tablero.
2. Quite los (4) tornillos Phillips de la parte inferior del bisel de la moldura del tablero.
3. Quite los (2) tornillos de cabeza hexagonal de 3/8" que sujetan la unidad central de fábrica y desconecte el cableado.

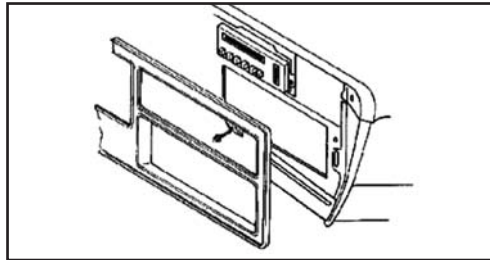

### **Chrysler Sebring/Dodge Avenger 1995-2000**

1. Desenganche el bisel de la moldura del radio y quite.
2. Quite los (2) tornillos Phillips #10 que sujetan la unidad central de fábrica y desconecte el cableado.

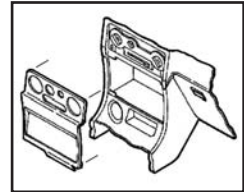

### **Chrysler Sebring (descapotable) 1995-2000**

1. Desenganche el bisel de la moldura del radio y quite.
2. Quite los (2) tornillos de cabeza hexagonal de 3/8" que sujetan la unidad central de fábrica y desconecte el cableado.

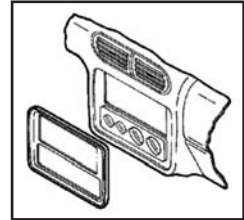

### **Chrysler Town & Country 1990-1995, Dodge Caravan/Plymouth Voyager 1984-1990**

1. Meta la mano detrás del cenicero y suelte la pestaña trasera de la carcasa del cenicero.
2. Quite los (2) tornillos del borde inferior del bisel de la moldura del radio.
3. Quite los (3) tornillos del borde superior del bisel de la moldura del tablero.
4. Suelte a presión el borde izquierdo del bisel y retírelo.
5. Quite los (2) tornillos de cabeza hexagonal de 3/8" que sujetan la unidad central de fábrica y desconecte el cableado.

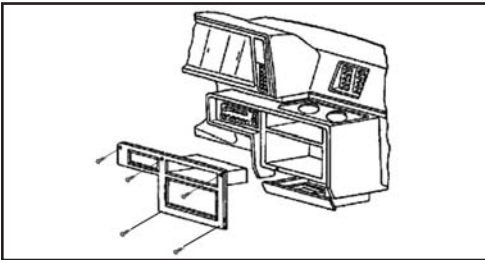

### **Dodge Caravan/Plymouth Voyager 1991-1995**

1. Quite el encendedor.
2. Usando una herramienta de remoción de panel, haga palanca para sacar el bisel de la moldura del tablero y retire.
3. Quite los (2) pernos de 3/8" que sujetan la unidad central de fábrica y desconecte el cableado.

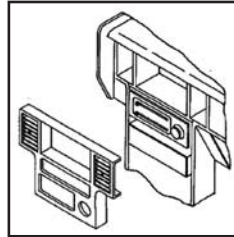

### **Dodge Caravan/Chrysler Town & Country/Plymouth Voyager 1996-2000**

1. Jale el cenicero hacia adelante. Suelte a presión la pieza de moldura de plástico localizada debajo del bisel de la moldura del radio y retire los (2) tornillos Phillips expuestos.
2. Quite los (2) tornillos Phillips de arriba de la apertura del radio.

### **Dodge Caravan/Chrysler Town & Country/Plymouth Voyager 1996-2000**

3. Desenganche el bisel de la moldura del tablero, desconecte el cableado del control de clima y retire el bisel.
4. Quite los (2) tornillos de cabeza hexagonal de 3/8" que sujetan la unidad central de fábrica y desconecte el cableado.

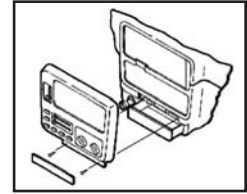

### **Dodge Charger/Plymouth Turismo 1983-1987**

1. Desenganche el bisel de la moldura del radio y quite.
2. Quite los (2) tornillos de cabeza hexagonal de 3/8" que sujetan la unidad central de fábrica y desconecte el cableado.

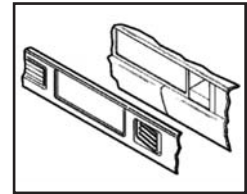



**Dodge Dakota  
1987-1996**

1. Quite los (8) tornillos de cabeza Torx del bisel de la moldura del tablero.
2. Quite los (2) tornillos Phillips de la moldura de la columna de dirección y retire.
3. Quite (1) tornillo Phillips expuesto de cada lado de la columna de dirección.
4. Desenganche el bisel de la moldura del tablero y quite.
5. Quite los (2) tornillos Phillips que sujetan la unidad central de fábrica y desconecte el cableado.

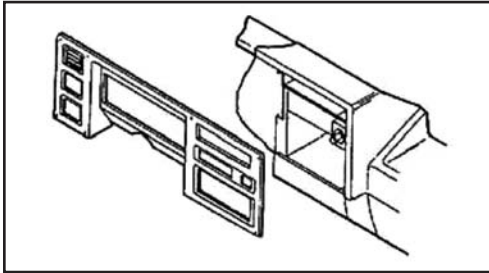
**Dodge Dakota  
1997-2000**

1. Desenganche todo el bisel de la moldura del tablero.
2. Quite los (2) tornillos de cabeza hexagonal de 3/8" que sujetan la unidad central de fábrica y desconecte el cableado.

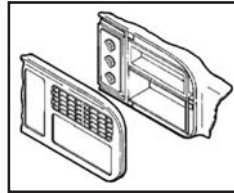
**Dodge Daytona  
1990-1993**

1. Jale hacia afuera el bisel de la moldura del tablero y retire.
2. Quite los (2) tornillos a cada lado de la consola inferior (esto permitirá retirar el radio con más facilidad).
3. Quite los (2) tornillos que sujetan la unidad central de fábrica y desconecte el cableado.

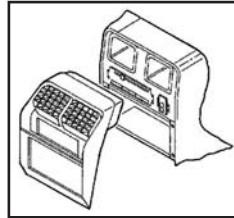
**Dodge Durango  
1997-2000**

1. Desenganche todo el bisel de la moldura del tablero.
2. Quite los (2) tornillos de cabeza hexagonal de 3/8" que sujetan la unidad central de fábrica y desconecte el cableado.

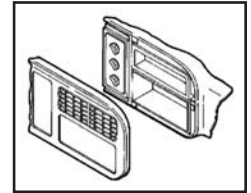
**Dodge Neon/Plymouth  
Neon 1994-1999**

1. Quite el cenicero.
2. Desenganche el bisel de la moldura del radio y quite.
3. Quite los (2) tornillos de cabeza hexagonal de 3/8" que sujetan la unidad central de fábrica y desconecte el cableado.

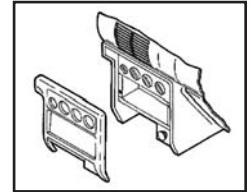

**Dodge Omni/024/Rampage  
1978-1982, Plymouth  
Horizon/TC3 1978-1982/  
Scamp 1983-1984**

1. Quite los (7) tornillos Phillips del bisel de la moldura del tablero y retire el bisel.
2. Quite los (2) tornillos de cabeza hexagonal de 3/8" que sujetan la unidad central de fábrica y desconecte el cableado.

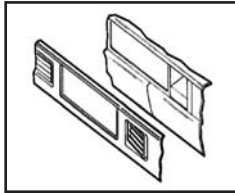
**Dodge Pickup/Ramcharger  
1974-1980, Plymouth  
Trailduster 1974-1980**

4. Desenganche el bisel y quite.
5. Quite los (2) tornillos de cabeza hexagonal de 3/8" que sujetan la unidad central de fábrica y desconecte el cableado.

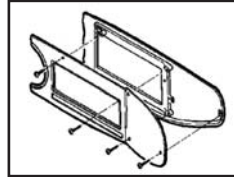
**Dodge Pickup/Ramcharger  
1981-1993, Plymouth  
Trailduster 1981**

- Dodge Pickup/Ramcharger  
1974-1980, Plymouth  
Trailduster 1974-1980**
1. Quite los (4) tornillos Phillips del borde superior del bisel de la moldura del tablero.
  2. Quite los (7) tornillos Phillips de la parte frontal del bisel de la moldura del tablero.
  3. Quite los (3) tornillos Phillips debajo del bisel de la moldura del tablero.

1. Quite los (5) tornillos Phillips del borde del bisel de la moldura del tablero.
2. Quite (1) tornillo Phillips de arriba de la apertura del radio.
3. Haga palanca hacia afuera en el borde inferior del bisel y retírelo.
4. Quite los (2) tornillos de cabeza hexagonal de 3/8" que sujetan la unidad central de fábrica y desconecte el cableado.

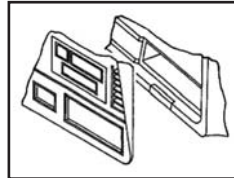
**Dodge Ram 1994-2001,  
Ram 2500/3500 2002**

1. Quite el cenicero. Quite el cenicero y los (2) tornillos Phillips expuestos en la cavidad del cenicero y retire el soporte del cenicero. Quite el portavasos.
2. Quite el cenicero y los (2) tornillos Phillips expuestos en la cavidad del portavasos y retire el soporte del portavasos.
3. Desenganche el bisel de la moldura del tablero; jale el bisel encima de la columna de dirección y quítelo.
4. Quite los (2) tornillos de cabeza hexagonal de 3/8" que sujetan la unidad central de fábrica y desconecte el cableado.

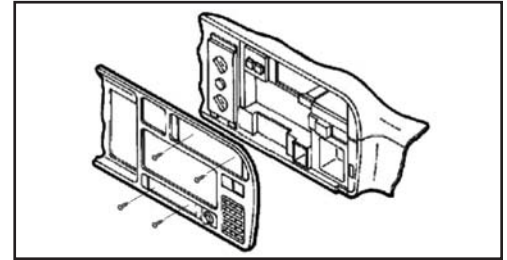

**Dodge Shadow/Plymouth Sundance 1987-1994**

1. Quite el cenicero. Desenganche el bisel de la moldura del tablero y quite.
2. Quite (1) tornillo Phillips de la moldura lateral de la consola y retire.
3. Quite los (2) pernos de cabeza hexagonal de 3/8" que sujetan la unidad central de fábrica y desconecte el cableado.

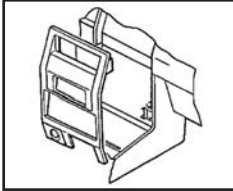
**Dodge Spirit/Plymouth Acclaim 1989-1995**

1. Desenganche el bisel de la moldura del tablero y quite.
2. Quite los tornillos que sujetan las piezas de moldura de la consola lateral.
3. Jale la pieza derecha de la moldura hacia afuera y quite (1) perno de cabeza hexagonal expuesto.
4. Quite (1) perno de cabeza hexagonal que sostiene la esquina inferior izquierda de la unidad central de fábrica y desconecte el cableado.

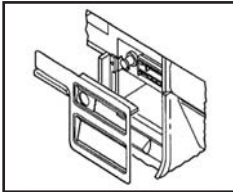
**Dodge Van/Plymouth Van 1978-2003**

1. Abra la guantera y retire los (2) tornillos Phillips expuestos.
2. Quite los (5) tornillos Phillips de la parte inferior del bisel de la moldura del tablero.
3. Suelte a presión el borde superior del bisel y retírelo.
4. Quite los (2) tornillos de cabeza hexagonal de 3/8" que sujetan la unidad central de fábrica y desconecte el cableado.

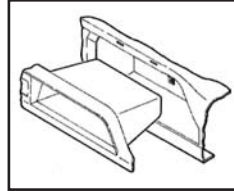
**Ford Aerostar 1985-1991**

1. Quite los (2) tornillos Phillips de la base del panel del tablero.
2. Haga palanca hacia abajo en las (2) pestañas localizadas en la parte superior del bisel de la moldura del radio y retire el bisel.
3. Quite los (4) tornillos que sujetan la unidad central de fábrica y desconecte el cableado.

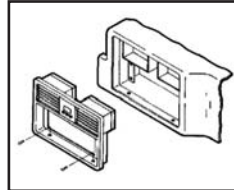
**Ford Bronco II/Ranger (mini) 1985-1988**

1. Quite los (4) tornillos Phillips del borde superior del bisel de la moldura del tablero.
2. Quite la perilla del interruptor de las luces, el encendedor y el cenicero.
3. Suelte a presión la moldura debajo del bisel de la moldura del tablero y retire los (4) tornillos expuestos. Quite los (4) tornillos que sujetan la unidad central de fábrica y desconecte el cableado.

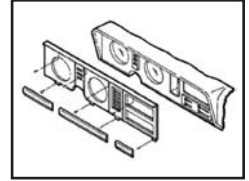
**Ford Crown Victoria/LTD 1979-1990, Mercury Grand Marquis/Marquis 1979-1990**

1. Abra el cenicero y retire los (2) tornillos Phillips expuestos.
2. Quite el bisel de la moldura del tablero.
3. Quite los (4) tornillos que sujetan la unidad central de fábrica y desconecte el cableado.

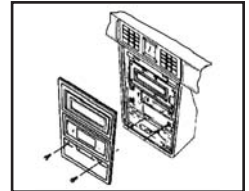

**Ford Thunderbird/Mercury Cougar 1985-1988**

1. Quite los (2) tornillos de la parte superior del bisel de la moldura del tablero.
2. Abra el cenicero y retire los (2) tornillos expuestos en la cavidad del cenicero.
3. Quite el bisel de la moldura del tablero. Quite los (4) tornillos que sujetan la unidad central de fábrica y desconecte el cableado.

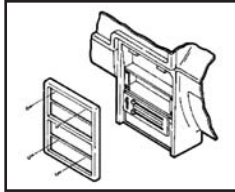
**Jeep Cherokee 1997-2001**

1. Desenganche el bisel de la moldura del tablero.
2. Quite los (2) tornillos #10 de cabeza hexagonal que sujetan la unidad central de fábrica y desconecte el cableado.

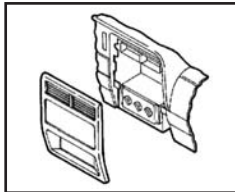
**Jeep Grand Cherokee 1993-1995**

1. Quite los (2) tornillos Phillips de la parte inferior del bisel de la moldura del tablero.
2. Quite los (2) tornillos Phillips de arriba de la apertura del radio.
3. Quite los (2) tornillos Phillips a la izquierda de la columna de dirección.
4. Quite (1) tornillo Phillips a la derecha de la
5. Desenganche el bisel de la moldura del tablero y desconecte el cableado.

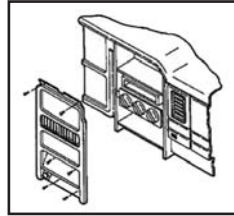
**Jeep Grand Cherokee 1996-1998**

1. Desenganche el panel del control de clima/limpiaparabrisas y retire.
2. Quite los (5) tornillos Phillips de la parte superior del bisel de la moldura del radio/conjunto de instrumentos.
3. Quite los (4) tornillos Phillips de la parte inferior del bisel de la moldura del radio/conjunto de instrumentos.

**Jeep Grand Cherokee 1996-1998**

4. Haga palanca hacia afuera en el borde inferior del bisel y retírelo.
5. Quite los (2) tornillos de cabeza hexagonal de 3/8" que sujetan la unidad central de fábrica y desconecte el cableado.

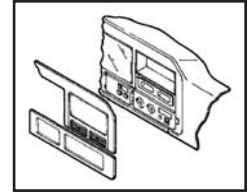
**Jeep Wrangler 1997-2002**

1. Quite el cenicero y (1) tornillo Phillips expuesto en la cavidad del cenicero.
2. Haga palanca hacia afuera sobre la cubierta superior del panel de instrumentos y retire los (2) tornillos Phillips expuestos.
3. Haga palanca hacia afuera en el borde inferior del bisel de la moldura del tablero y retírelo
4. Quite los (2) tornillos de cabeza hexagonal de 3/8" que sujetan la unidad central de fábrica y desconecte el cableado.

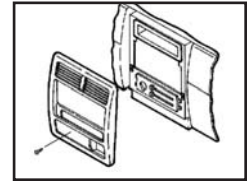

## Lincoln Continental 1985-1987

## Notas

1. Quite los (2) tornillos Phillips de debajo de la apertura del radio.
2. Abra el cenicero y retire los (2) tornillos Phillips #8 (no es necesario retirar el tornillo central).
3. Desenganche el bisel de la moldura del tablero y quite.
4. Quite los (4) tornillos de cabeza hexagonal que sujetan la unidad central de fábrica y desconecte el cableado.

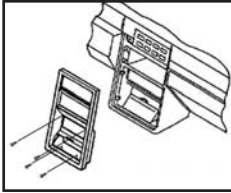

---

---

---

---

---

---

---

---

---

---

---

---

---

---

---

---

---

---

---

---

---

---

---

---

---

---

---

---

---

---

---

---

## Lincoln Mark VII 1984-1989

1. Haga palanca hacia afuera el bisel de la moldura del tablero y retire.
2. Quite los (4) tornillos de lámina de cabeza hexagonal de 5mm que sujetan la unidad central de fábrica y desconecte el cableado.

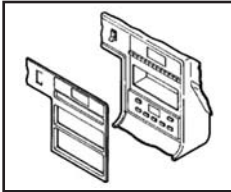





**INST-6000**

**Notas**

---

---

---

---

---

---

---

---

---

---

---

---

---

---

---

---

---

---

---

---

---

---

---

---





## INSTRUCCIONES DE INSTALACIÓN PARA LA PIEZA INST-6000



REV. 9/3/2014 INST-6000



**EL CONOCIMIENTO ES PODER**  
Mejore sus habilidades de instalación y fabricación inscribiéndose en la escuela de dispositivos electrónicos móviles más reconocida y respetada de nuestra industria. Regístrese en [www.installerinstitute.com](http://www.installerinstitute.com) o llame al 800-354-6782 para obtener más información y avance hacia un futuro mejor.



**Metra recomienda técnicos con certificación del Programa de Certificación en Electrónica Móvil (Mobile Electronics Certification Program, MECP).**